

BEND-TECH DRAGON A400

Start-Up and Training Manual Part 2: Machine Start-Up and Walkthrough

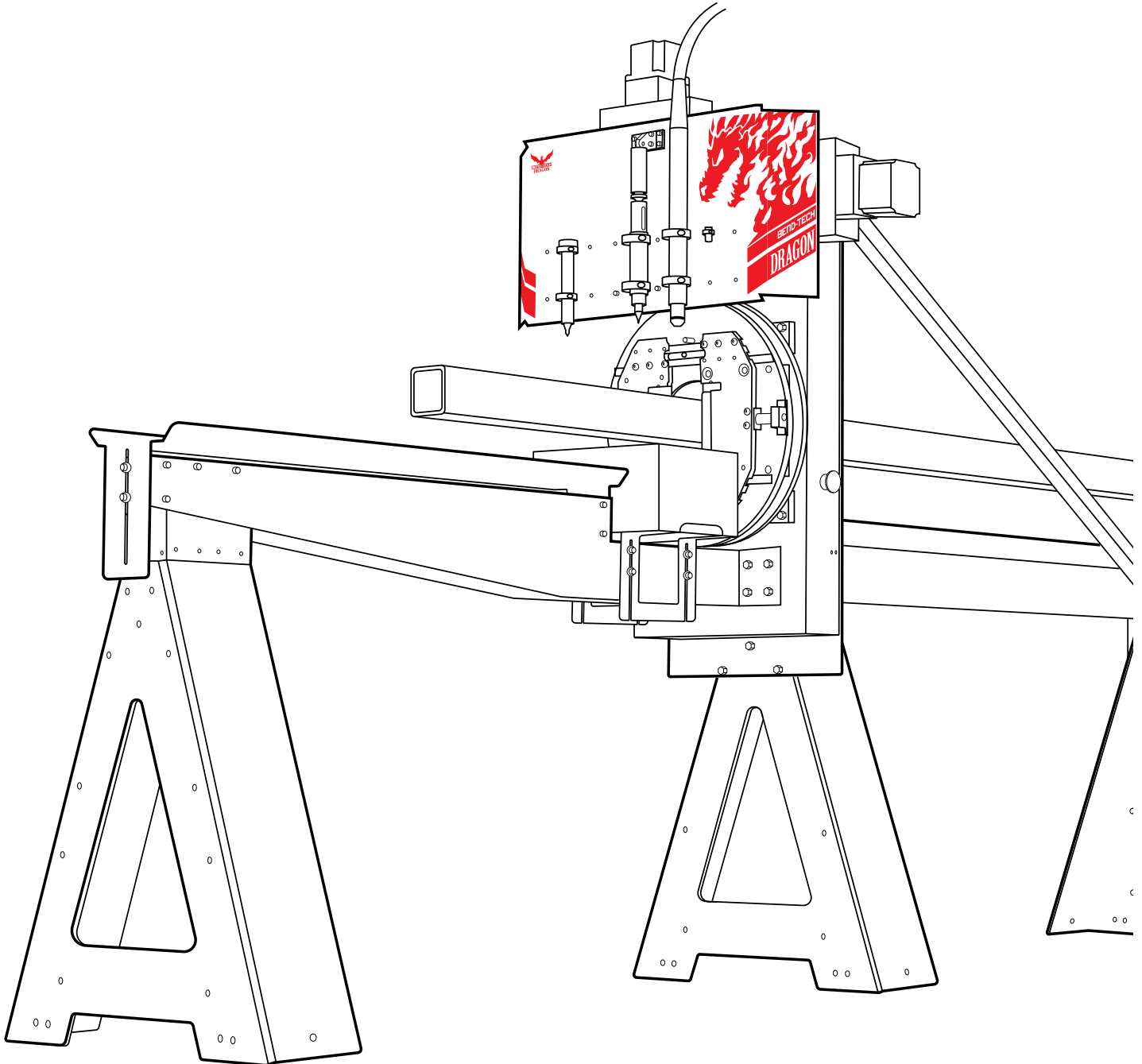

©2020 Bend-Tech LLC

All rights reserved. The information in this manual is subject to change without notice. Bend-Tech LLC strives to produce the most complete and accurate information regarding its products. We are constantly working to improve and advance our products to increase performance, user satisfaction and experience. Bend-Tech LLC assumes no responsibility for errors or omissions regarding this manual. Bend-Tech LLC assumes no liability for damages resulting from the use of the information contained in this publication.

Dragon A400

Start-Up and Training Manual Revision 4

English
Original Instructions

July 2020

Bend-Tech LLC
729 Prospect Ave.
Osceola, WI 54020 USA

(651) 257-8715
www.bend-tech.com
support@bend-tech.com

Contents

Contentsiv

01

Setup Inspection..... 7

- 1.1 General Overview 7
- 1.2 Rail 8
 - 1.2.1 Rail Assembly 8
 - 1.2.2 Checking Rail Level. 8
 - 1.2.3 Checking Rail Straightness 8
 - 1.2.4 Rail Splices 8
- 1.3 Trolley. 9
 - 1.3.1 Trolley Cover 9
 - 1.3.2 Trolley Bearing Adjustment 9
- 1.4 Drive Belt Alignment. 10
 - 1.4.1 Drive Pulley Spacing 11
 - 1.4.3 Drive Belt Clamp 11
- 1.5 Drive Belt Tension Procedure 12
 - 1.5.1 Checking Drive Belt Tension .. 12
 - 1.5.4 Drive Belt Tension Nut. 13
 - 1.5.5 Adjusting Belt Tension 14
 - 1.5.6 Locking Drive Belt Tension ... 14
- 1.6 Control Box 15
 - 1.6.1 C Axis Control Box. 16
 - 1.6.2 Main Power Cord. 16
 - 1.6.3 Main Power Switch 16
 - 1.6.4 Main Power Fuses. 16

- 1.6.5 Breakout Board 17
- 1.6.7 Motor Cables 18
- 1.6.8 Motor Location and Operation Index. 18
- 1.6.9 Axis Sensor Cables 18
- 1.6.10 E-Stop Cables 19
- 1.6.11 Ethernet Port 19
- 1.6.12 Air Line Connection 19
- 1.7 Power and Control Connections ... 20
 - 1.7.1 Cable Connections 20
 - 1.7.2 Motor Connections. 20
 - 1.6.13 Laser Cord. 20
 - 1.6.14 Tool Connections 20
 - 1.7.3 Motor Connector Check. 21
 - 1.7.4 Sensor Connections 21
 - 1.7.5 Air Line Connections 21
 - 1.7.6 Ground Cable 22

02

Machine Walk Through 23

- 2.1 Machine Overview 23
- 2.2 Gate 23
 - 2.2.1 Gate Overview. 24
 - 2.2.2 Gate Eccentric Bearing 25
 - 2.2.3 Gate Lead Screws 25
 - 2.2.4 Gate Adjustment 26
 - 2.2.5 Gate Bearings 26

- 2.2.6 Gate Rollers 26
- 2.2.7 Gate Clamp 26
- 2.3 Material Support Lift 27
 - 2.3.1 Material Support Lift Overview 27
 - 2.3.2 Material Support Lift Operation 28
 - 2.3.3 Air Cylinder Adjustment 28
- 2.4 Toolhead 29
 - 2.4.1 Toolhead Overview 29
 - 2.4.2 Toolhead Actuators 30
 - 2.4.3 Marker 30
 - 2.4.4 Engraver 30
 - 2.4.5 Engraver Air Regulators 31
 - 2.4.6 Engraver Bleeder Valve 31
 - 2.4.7 Torch 31
 - 2.4.8 Laser 31
- 2.5 Electrical Components 32
 - 2.5.1 Electrical Components Overview 32
 - 2.5.2 Emergency Stops (E-Stops) 32
 - 2.5.3 E-Stop Wiring 32
 - 2.5.4 Homing Sensors 33
 - 2.5.5 Homing Sensor Designations and Locations 33
 - 2.5.6 Homing Sensor Cable Connections 34
- 2.6 Motor Cable Connections 34
 - 2.6.1 Motor Cable Connection Overview 34
- 2.7 Hypertherm Unit 35
 - 2.7.1 Hypertherm Overview 35

- 2.7.2 Hypertherm Cable 35
- 2.7.3 Ground Connection 35
- 2.7.4 Amperage 36
- 2.7.5 Air Supply 36
- 2.7.6 Gas 36
- 2.7.7 Consumables 37
- 2.7.8 Consumables Part List 37

03

Machine Control Startup..... 39

- 3.1 Overview of Software Operation 39
 - 3.1.1 Ethernet Connection 39
- 3.2 Booting Up The Dragon A400 40
 - 3.2.1 Power On Computer 40
- 3.3 Power On Control Box 41
 - 3.3.1 Main Power Switch 41
 - 3.3.2 Green Power Button 41
 - 3.3.3 Launch Bend-Tech 7X 42
 - 3.3.4 Dragon A400 Software Color Designations 42
 - 3.3.5 Bend-Tech Launcher 42
 - 3.3.6 Machine Control 42
 - 3.3.7 Mach3 Machine Control 43
 - 3.3.8 Enable Machine 43
- 3.4 Jog Controls System Check 44
 - 3.4.1 Open Jog Controls 44
 - 3.4.2 Motor Location and Operation Index 44
 - 3.4.3 Jogging the Machine 45
- 3.5 Homing The Machine 45

Contents

3.5.1 Homing An AXIS	45
3.5.2 Axis Definition Table.	46
3.5.3 Jog The Trolley	46
3.5.4 Home All Axis.	47
3.6 Hypertherm	47
3.6.1 Hypertherm Power Switch	48
3.6.2 Hypertherm Cut Type.	48
3.6.3 Hypertherm Air Supply.	49
3.6.4 Hypertherm PSI Settings	49
3.6.5 Hypertherm Cut Settings	49

Setup Inspection

1.1 General Overview

After assembling the Dragon A400 it is important to conduct an initial inspection of components to ensure proper setup. An improperly assembled machine can create numerous problems once it comes time to power up the machine and begin operation.

This chapter is set up as a procedural. Following this procedure will ensure the Dragon A400 is set up properly before it is powered up for operation.

! Caution !



It is important to inspect the machine before it is powered up. Handling electrical fittings can cause injury to the Operator. Always inspect electrical connections while the machine is powered down, preferably disconnected from power sources.



It is often the case that a flaw in the operation of the machine is the result of improper setup. Initial inspection is critical to eliminating setup variables in the troubleshooting process.

1.2 Rail

The Rail allows the Dragon A400 to precisely position material during the cutting process. The Rail is mounted on the Rail Beam, which forms the “backbone” of the machine. Ensuring the Rail is assembled correctly and is straight and level is critical to the overall operation of the machine.

1.2.1 Rail Assembly

The Rail is assembled in sections. The number of sections will depend on the length of the machine. There can be up to four Rail sections on the Dragon A400. It is critical that these sections are straight and level to insure proper operation of the Trolley, and proper feed of material to the Toolhead. If the Rail is not straight and level it can affect the operation of the Drive Belt and/or damage the Drive Belt and Drive Belt system.

1.2.2 Checking Rail Level

Each Rail section should be checked for side-to-side level, and level along its length, using a bubble level. If the Rail needs to be adjusted the Technician can use the Swivel Levelers provided with the Dragon A400. The Swivel Levelers should be installed upon assembly. If the machine is bolted to the floor, the bolts securing the Floor Brackets should be loosened enough so the legs can be adjusted appropriately to level the Rail, then re-tightened.



When equipped with the Cooling System it is recommended that the back of the Rail be set slightly higher than the front

1.2.3 Checking Rail Straightness

The Rail should be checked for straightness along its length. The most accurate way to check for Rail straightness is by using a laser tool. However, a taut string will also work to check straightness. If the Rail is not straight the Technician will need to straighten the Rail by aligning each individual Rail section beginning at the front of the machine, using the front Rail section as the benchmark.

1.2.4 Rail Splices

Ensure that each Rail Splice intersects with the next as seamlessly as possible. Ensure that all of the Rail Splices are fastened properly to the Rail.



Aligning the Rail Splices is one of the most difficult and time-consuming parts of the assembly process. Ensuring Rail Splices are straight and even is critical to the setup of the Dragon A400. Bend-Tech recommends experienced personnel perform the Rail Splice installation.

1.3 Trolley

The Dragon A400 uses the Trolley to position the material during the machine's cutting process. Ensuring the Trolley is assembled correctly, and is mounted on the Rail correctly, is critical to the operation of the machine.



The Dragon A400 is shipped with the Trolley Cover separate from the Trolley. Bend-Tech recommends leaving the Trolley Cover off the machine in order to conduct initial machine inspection.

1.3.1 Trolley Cover

In order to inspect for proper Trolley motor and sensor cable connections, the Trolley Cover must not be installed on the machine. The machine is shipped without the Trolley cover installed on the Trolley.

1.3.2 Trolley Bearing Adjustment

The Trolley is adjusted using the two eccentric bearings located underneath the mounting plate on the left side. The bearings on the right side of the Trolley are stationary (not adjustable). If the Technician attempts to rock the Trolley from side-to-side on the Rail there should be no play in it. The Trolley should be snug to the Rail. If there is any play in the Trolley it will be necessary to adjust the eccentric bearings located on the bottom of the Trolley. The Operator should use a $\frac{3}{4}$ in. wrench to adjust the Trolley eccentric bearings.

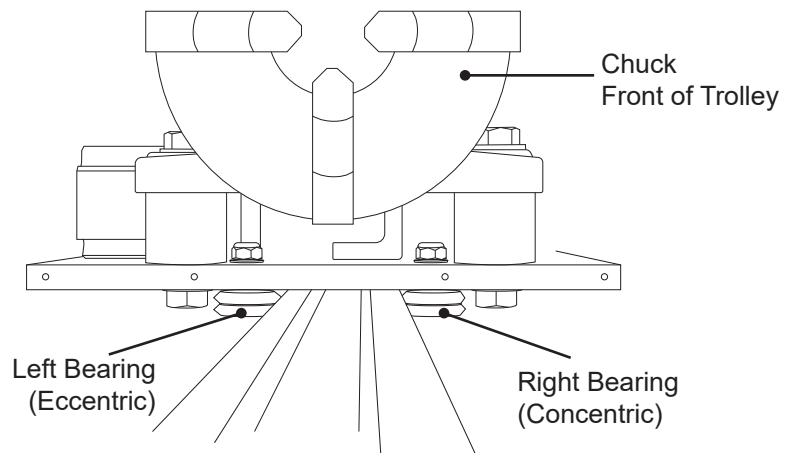

1.3.3 Trolley Operation

If there is no play in the Trolley on the Rail, remove tension from the Drive Belt by removing Drive Belt Adjustment Block nuts. Slide the Trolley along the length of the Rail to ensure smooth operation. If it seems tight, it may be necessary to adjust the eccentric bearings to provide smoother operation. If the Trolley binds anywhere on the Rail ensure the Rail is level and straight as outlined in section 1.2. If it is determined that the Rail is level and straight but the Trolley is still binding, it will be necessary to inspect and measure the Rail to ensure it is not out of alignment.

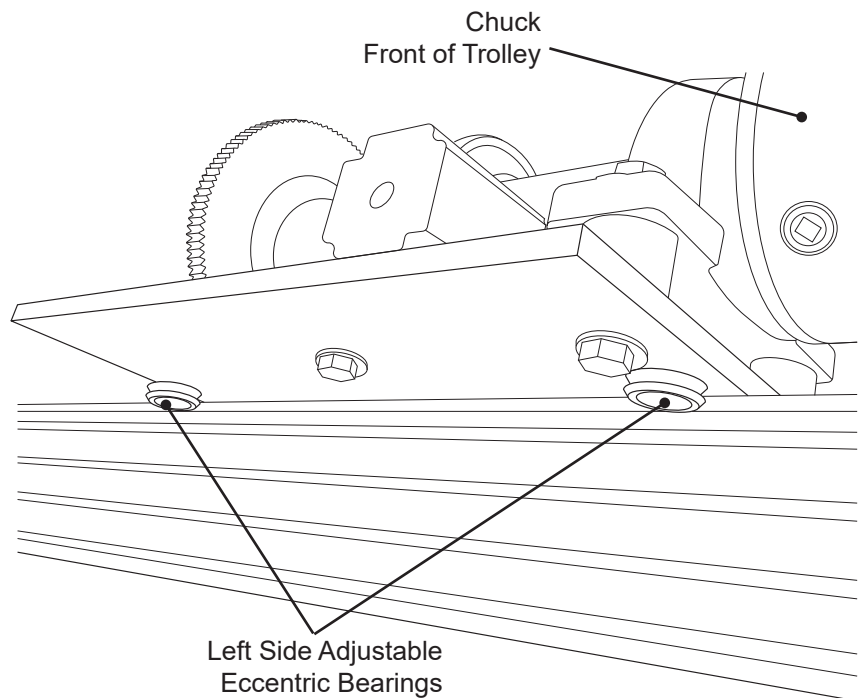

1.4 Drive Belt Alignment

If the Drive Belt Pulley is not aligned properly it will cause the Drive Belt to ride improperly on the idler pulleys and potentially lead to Drive Belt derailing, flipping on the pulleys, pushing the Drive Belt Pulley washer off the Drive Belt Pulley, Drive Belt damage, or Drive Belt failure.



Ensuring the Drive Belt is mounted on the machine correctly and tensioned correctly is important to the operation of the Trolley.

1.4.1 Drive Pulley Spacing

To check Drive Pulley spacing, use a Vernier caliper to measure the distance from the inside of the Drive Pulley to the X Axis motor mount surface. The distance should measure $\frac{3}{8}$ in. or .375 in. A slight difference in measurement is acceptable but it should be close to the specified measurement.

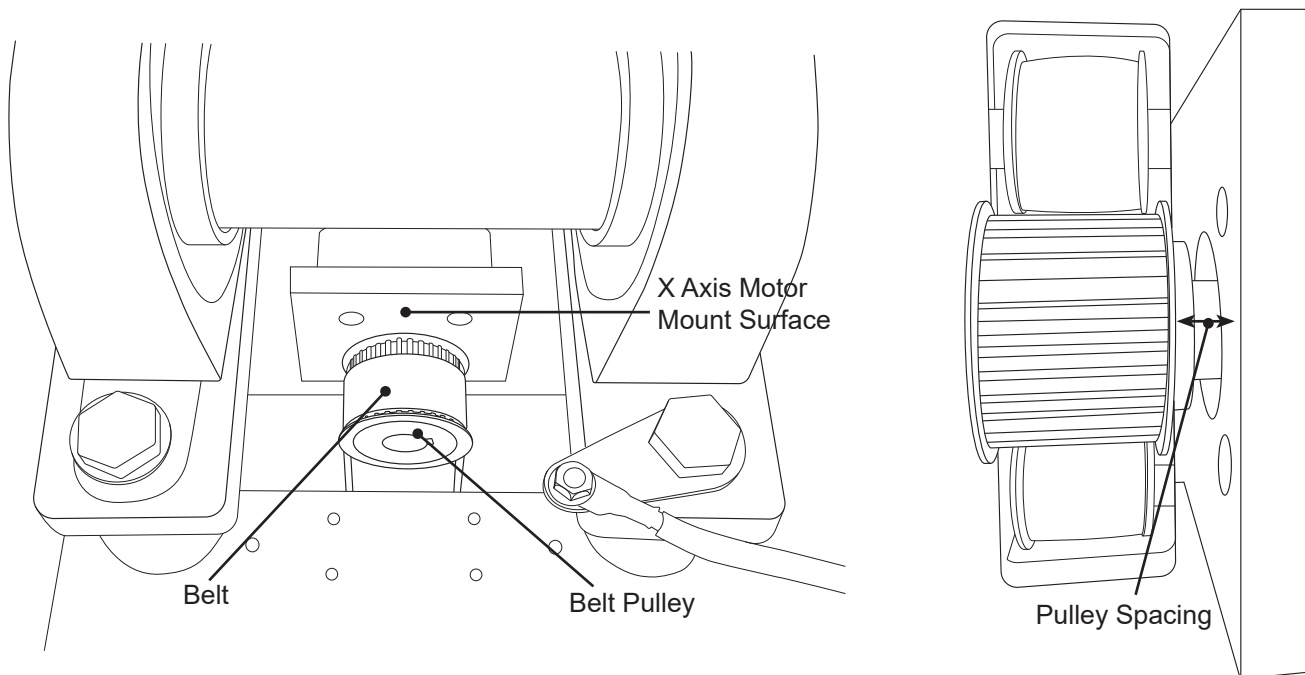

Motor Mount Plate Flush With Edge	.168 in.
Motor Mount Plate Set Back From Edge	.375 in.

1.4.3 Drive Belt Clamp

Before tensioning the Drive Belt, ensure it is secured in the rear Clamp Block properly. The Drive Belt should be straight within the Drive Belt Clamp. The Drive Belt should be positioned in the Clamp Block so it is butting up against the Clamp Block fasteners, as far away from the Rail as possible. The Clamp Block should be securely tightened by hand.

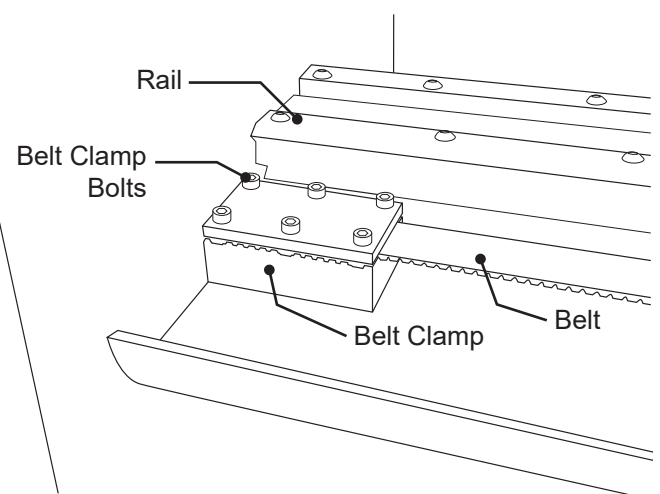

1.5 Drive Belt Tension Procedure

The Operator should ensure the Drive Belt is tensioned properly. If Drive Belt tension is not set to specification it can result in inconsistent machine operation. It is important to tension the Drive Belt to ensure consistent operation of the Dragon A400. Before setting Drive Belt tension ensure all steps in section 1.4 have been performed.



The Drive Belt Tension procedure is also outlined in the Dragon A400 Assembly Manual, Chapter 4, section 4.3.



When checking or adjusting the Drive Belt ensure the Trolley is positioned at the mid-way point on the Rail.

1.5.1 Checking Drive Belt Tension

Lay a tape measure on the cable track with 0 on the ruler positioned where the Drive Belt enters the Drive Belt Clamp Block. Using the Belt Tension Tool from the Miscellaneous box, position the tool one foot from the Drive Belt Clamp Block. Place a finger under the Drive Belt two feet from the end of the Drive Belt Clamp Block. Push straight down on the Belt Tension Tool with the right index finger while supporting the Drive Belt with the left hand. When the Belt Tension Tool clicks, observe where the top face of the lever crosses the plane on the body of the tool. This position indicates belt tension.

Belt Tension	120 lbs
--------------	---------

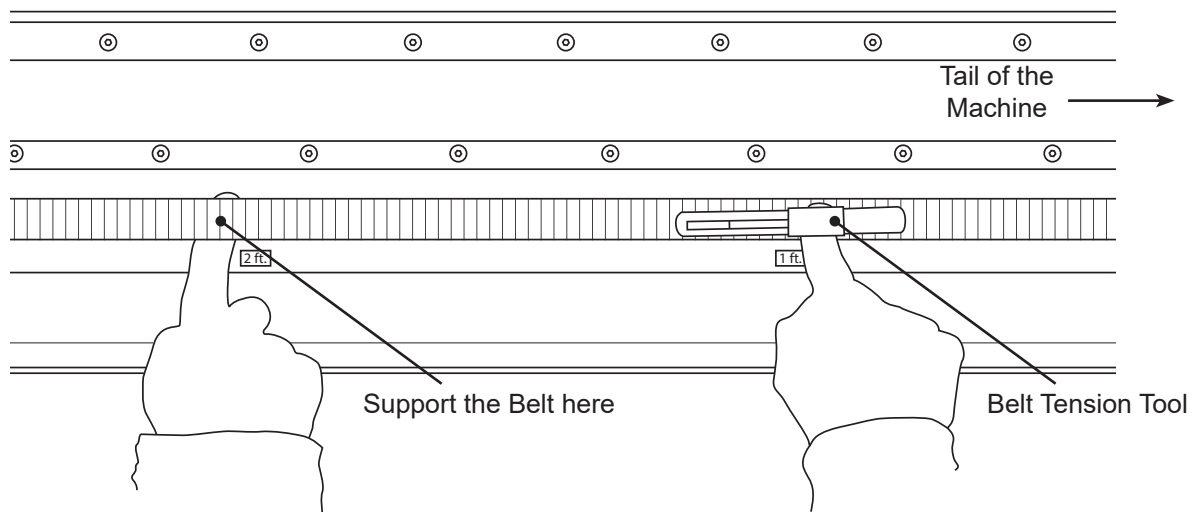

Improper Drive Belt tension will lead to inconsistent Trolley operation.

1.5.4 Drive Belt Tension Nut

The Clamp Block is fitted with a threaded adjustment extension that fits through the plate on the Tail of the Dragon A400. There are two nuts on the threaded adjustment extension, one is used to adjust the Drive Belt tension and the other is tightened against the adjustment nut to lock tension in place.

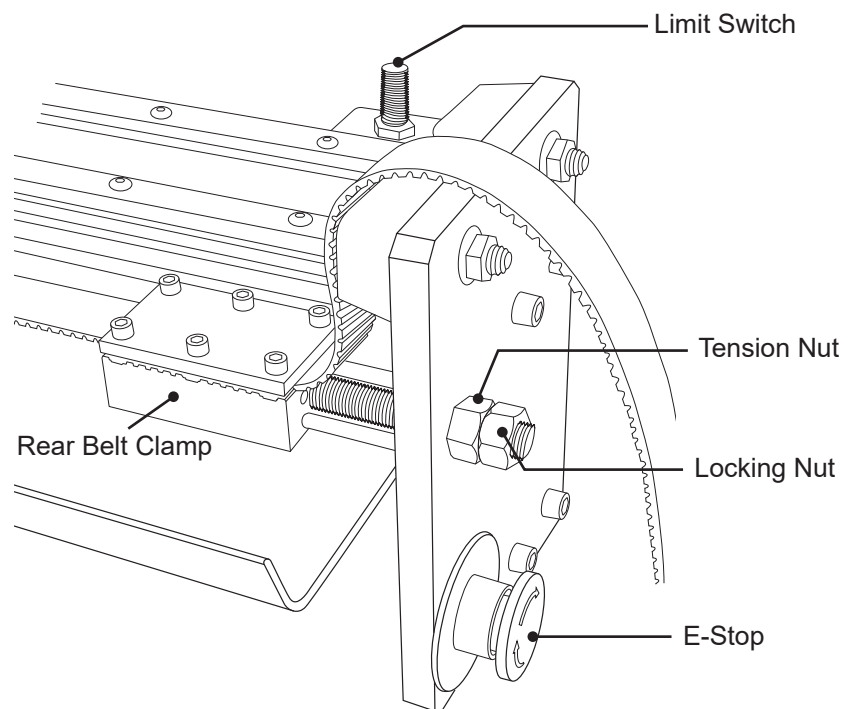

1.5.5 Adjusting Belt Tension

Using a $\frac{3}{4}$ in. wrench or socket, loosen the outer locking nut. Once loose, the Operator should be able to remove the locking nut by hand. To add tension to the Drive Belt, use a $\frac{3}{4}$ in. wrench or socket to turn the adjustment nut clockwise. To decrease Drive Belt tension turn the adjustment nut counterclockwise.

! Warning !



To avoid over-tensioning and possibly damaging the Drive Belt, check Drive Belt tension several times during the tensioning process.

1.5.6 Locking Drive Belt Tension

To lock in Drive Belt tension, thread the second $\frac{3}{4}$ in. nut onto the Drive Belt Tension adjuster. Holding the adjustment nut with a $\frac{3}{4}$ in. wrench, tighten the locking nut with a $\frac{3}{4}$ in. socket and ratchet or $\frac{3}{4}$ in. wrench against the adjustment nut slightly by turning it clockwise.

1.6 Control Box

The Control Box is mounted to the Dragon A400 at the Bend-Tech Manufacturing Facility. Ensure the Control Box is securely mounted in its location on the rear side of the third support leg from the front of the machine. Ensuring the Control Box is properly and securely mounted is critical to long-term functioning of its internal components and the Dragon A400. Ensure all cables are properly inserted and secured in their respective connectors.



To open the Control Box, use a large, flat blade screwdriver to turn the Control Box latch.

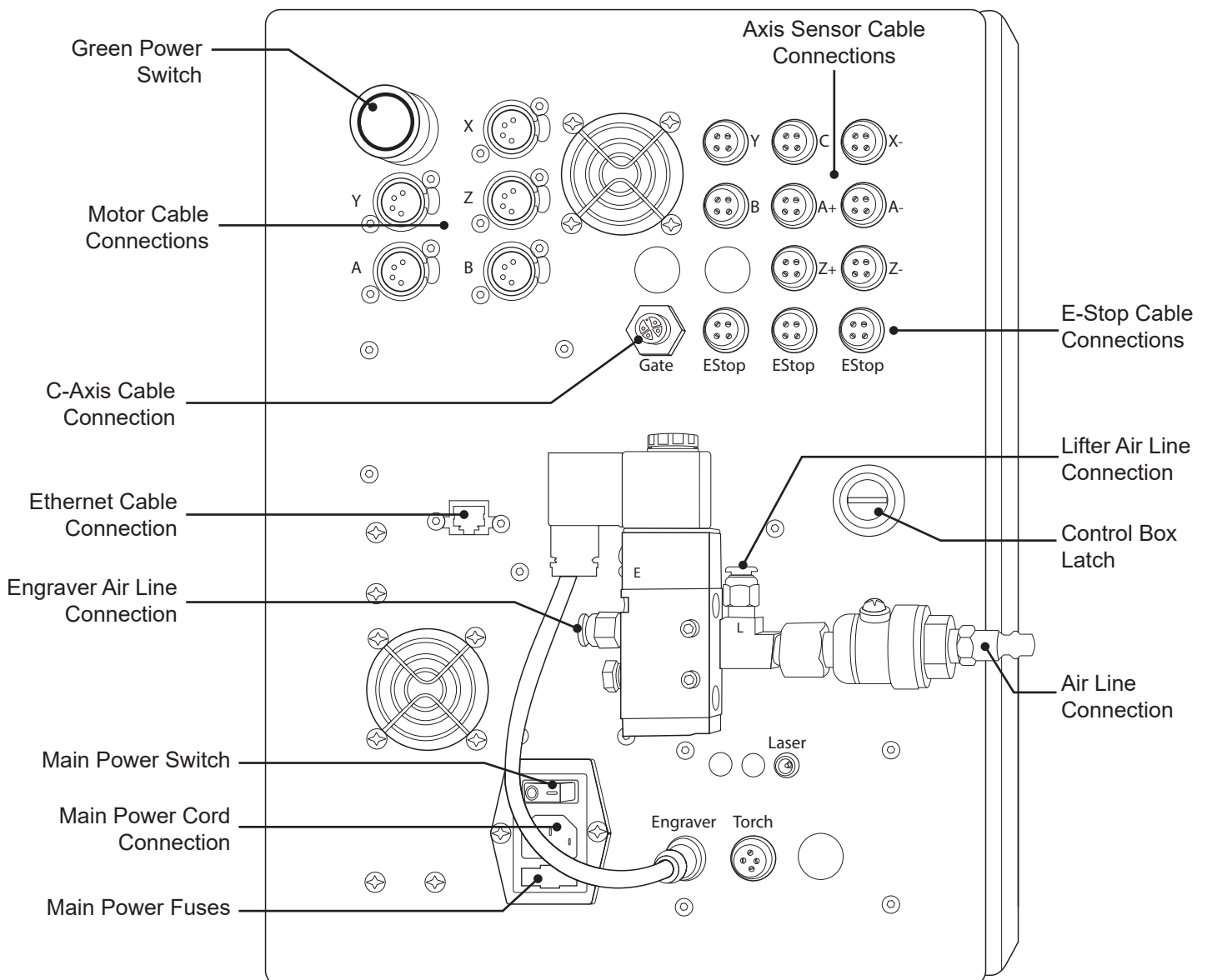



Not all machines will use the C and Gate connections.

1.6.1 C Axis Control Box

On Dragon A400 machines with a Powered Gate, the Control Box will be equipped with a C Axis Control Box piggybacked onto the Control Box. Ensure the C Axis Control Box is securely mounted on the Control Box and that the cables are tightened securely in their connections.

1.6.2 Main Power Cord

The Main Power Cord connects to the Control Box in the black hexagonal port just under the Engraver (E) Air Line Connection. Ensure the Main Power Cord is seated in its connection.

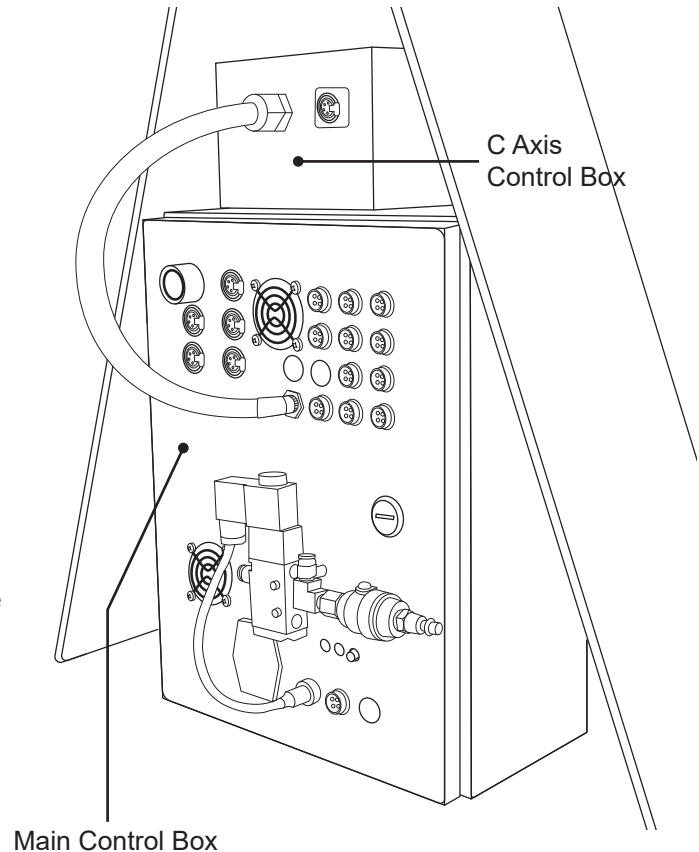

1.6.3 Main Power Switch

The Main Power Switch is located just above the Main Power Cord. The Main Power Switch should be off (the O side depressed) while inspecting and servicing the machine.

1.6.4 Main Power Fuses

The Main Power Fuse is located in a slot just below the Main Power Cord. To access the Main Power Fuse, remove the Main Power Cord from its socket and use a finger to slide out the Main Power Fuse holder. For Main Power Fuse location see Control Box diagram, section 1.6.



The Main Power Fuse holder has two fuse locations. The inner fuse is the Main Power Fuse, the outer is a replacement Main Power Fuse.



The Main Power Fuse is a 10A, 120VAC fuse. Ensure any replacement fuses are 10A, 120VAC.

1.6.5 Breakout Board

The Breakout Board should be properly seated in the motor drivers. Open the front cover of the Control Box. Locate the red circuit board in the top left of the Control Box. This is the Breakout Board. Press on the Breakout Board firmly to ensure it is seated into each motor driver. No other inspection is necessary within the Control Box.

! Caution !



Ensure power is disconnected from the machine before opening the Control Box.

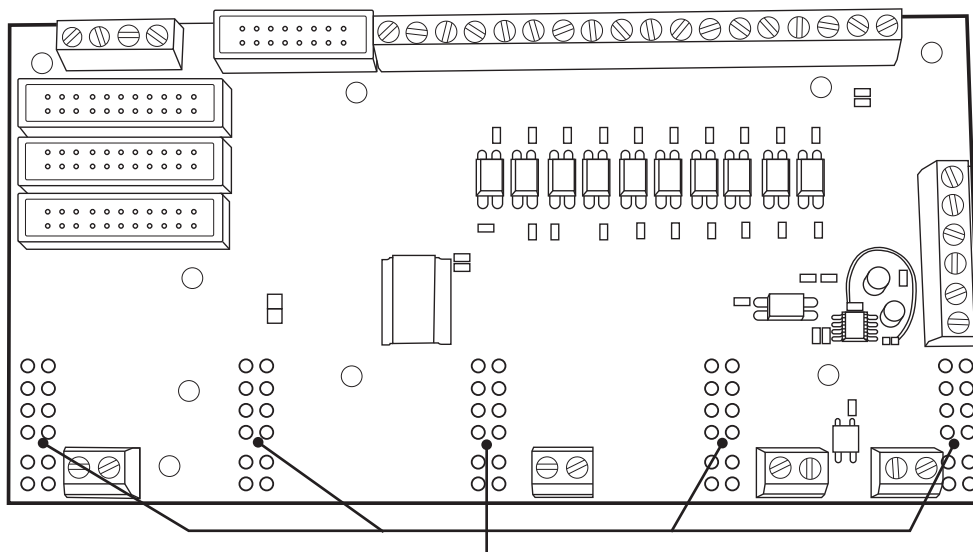

Press Here when checking the Breakout Board

1.6.7 Motor Cables

Motor Cable connections are grouped in the top left corner of the Control Box cover. There are five Motor Cables connected to the Control Box. Powered Gate machines have a Powered Gate Control Box with a separate C Drive motor cable. Ensure all Motor Cables are securely inserted at their Control Box connections and that their retaining clips are in place. If it is necessary to remove a Motor Cable it is critical to the operation of the machine that they be re-connected in their respective socket. Failure to do this will result in improper function of the machine and could possibly damage the machine.

1.6.8 Motor Location and Operation Index

Axis	Location	Operation
X	Trolley	Moves Trolley forward/backward
Y	Chuck	Rotates chuck clockwise/counter clockwise
Z	Tool Head	Moves Tool Head left/right
A	Tool Head	Moves Tool Head up/down
B	Material Support	Raises/lowers material support
C	Front Gate	Rotates Front Gate clockwise/counter-clockwise

1.6.9 Axis Sensor Cables

Motor Sensor cable connections are grouped in the top right of the Control Box cover. Ensure all Motor Sensor cables are securely seated at their Control Box connections and that they are tight. If it is necessary to remove a Motor Sensor cable it is critical to the operation of the machine that they be re-connected in their respective socket. Failure to do this will result in improper function of the machine and could possibly damage the machine.

! Warning !



Ensure the Main Power Switch is off (O) before handling Axis Sensor Cables.

1.6.10 E-Stop Cables

There are three E-Stop cables located in the upper right corner of the Control Box. The E-Stop cables are at the bottom of the group of cables located in that position. Assure the E-Stop Cables are securely seated and tightened in their Control Box connections.



While there are four E-Stop buttons, only three E-Stop cables connect at the Control Box. It does not matter in what order the E-Stop cables are connected at the Control Box.

1.6.11 Ethernet Port

The Ethernet Port is located near the center of the Control Box. Ensure the Ethernet cable that connects the Dragon A400 computer to the Control Box is connected and seated in the Ethernet Port cable receptacle, and that it is securely clipped in place.



Ensure the Ethernet cable is connected directly to the computer. Do not use adapters. A link light at the Ethernet port indicates proper connection.



It is important to route the Ethernet cable away from the Torch cable as well as other electrical feed to ensure proper signal, and avoid electrical interference

1.6.12 Air Line Connection

The air line connection for the machine is located in the bottom central portion of the Control Box cover. It consists of:

- Air compressor connection
- Engraver and Material Support Lift Connections
- Air Solenoid
- Engraver mechanism

The air line that will feed the Dragon A400 Engraver and Material Support Lift should be connected to the fittings located near the center of the Control Box. Ensure all air lines and air line fittings are tight and leak-free.

1.6.13 Laser Cord

The Laser Cord plugs into the Control Box just below the air line assembly fitting. The Laser Cord has a red plastic identification fitting on the wire connection to identify it. Assure the Laser Cord is seated in its connection.

1.6.14 Tool Connections

The tool connections for the Dragon A400 are located at the bottom right of the Control Box. The Engraver uses the left hand connection, the Torch uses the center connection. The Torch cable should run to the Torch power supply.

1.7 Power and Control Connections

The Dragon A400 Drive Motors are connected to the Control Box using Drive Motor Cables. Homing Sensors are connected to the Control Box using Homing Sensor Cables. Air-powered components are connected to the Control Box using plastic air lines. The Torch is grounded through the Trolley via a Ground Cable. Ensuring all cables and connections are secure is important to maintaining consistent and long-term operation of the machine.

1.7.1 Cable Connections

There are two types of electrical cable connections on the Dragon A400 - Motor Connections and Sensor Connections. These connectors are easily identifiable by their size - Motor Connectors are .75 in. diameter, sensor connectors are .375 in. diameter.

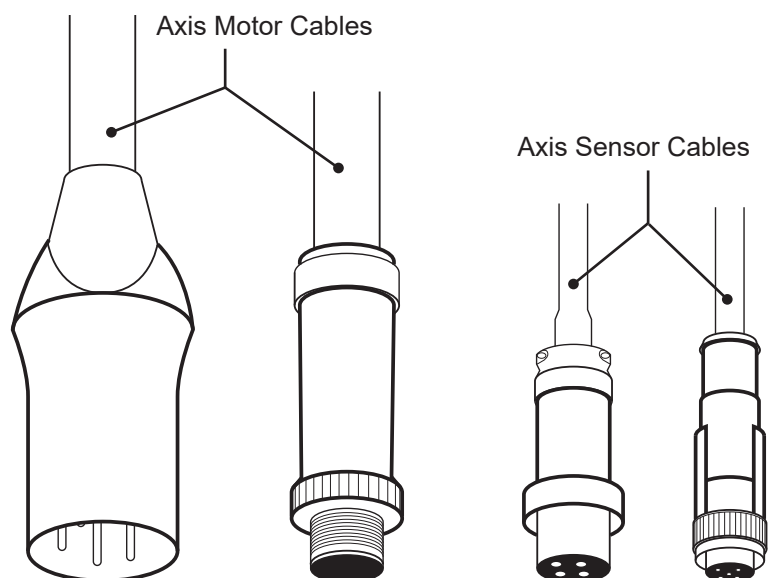

1.7.2 Motor Connections

Motor Connections are achieved via GX-type cable connectors. The Dragon A400 is shipped with all cables connected on the machine. No cables will be connected at the Control Box.

1.7.3 Motor Connector Check

Insuring the GX connections for the motors are secure at all connection points is critical to the operation of the machine. Proper tightness for the GX connector should be achieved by hand as tightening with wrenches or other tools can damage the connector.

1.7.4 Sensor Connections

Sensor cable connections are achieved via GX-style cable connectors. Insuring the GX connections for the motors are secure at all connection points is critical to the operation of the machine. Proper tightness for the connector should be achieved by hand, as tightening with wrenches or other tools can damage the connector.

! Caution !



It is possible for improperly fitted GX connectors to overheat and melt. This can damage the connector and affect the operational status of the machine. In extreme cases it could cause a risk of fire.



While using tools is not recommended when tightening GX connectors, sometimes GX connectors may require tools to get them loose. Should this issue arise, care should be taken not to damage the connectors.

1.7.5 Air Line Connections

Air line connections are achieved via pneufit, push-in style connectors. The plastic air lines that power various components on the Dragon A400 push into the respective pneufit connector to achieve connection. It is important to insure that all air line connections are securely seated and not leaking at each connection point for proper machine operation.

1.7.6 Ground Cable

The Ground Cable is key to proper operation of the Torch. It should be securely connected to its place on the Trolley. The nut connecting the Ground Cable should be tight, and is pre-torqued during assembly by Bend-Tech setup technicians. It is not necessary for the Technician or Operator to alter the pre-assembled Ground Cable connection. If the Ground Cable is improperly tightened or its connection is altered the Torch may not fire and/or injury or damage to the machine and its operator or bystanders may result.

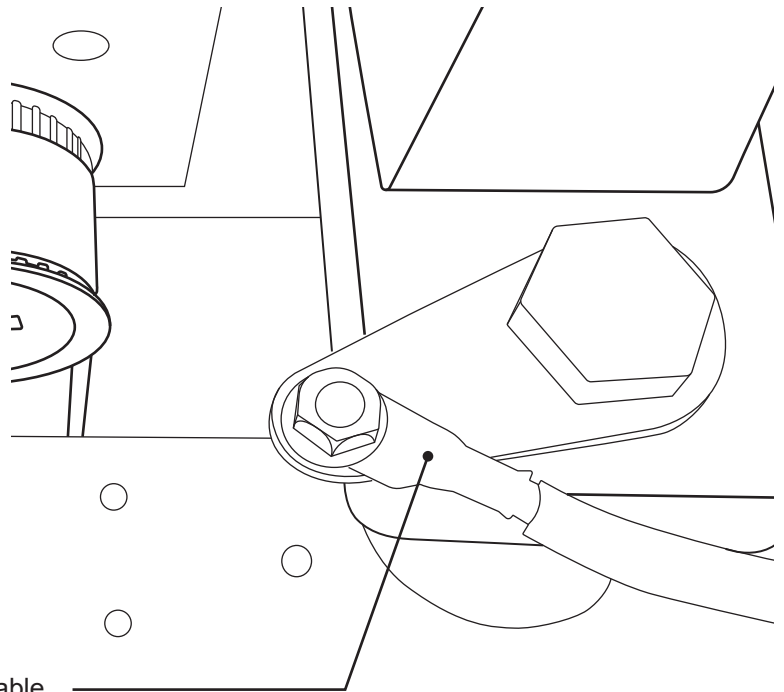

Ground Cable
Connection on Trolley

! Warning !



The Ground Cable provides a direct ground from the plasma cutting machine to the material being cut. Altering the Ground Cable connection could injure the Operator or observers. Altering the Ground Cable connection can affect the overall performance of the machine.

Machine Walk Through

02

2.1 Machine Overview

The Dragon A400 consists of many unique designs and part operations. For optimal performance, it is important for the Operator to familiarize themselves with the function of all of these components.

This Chapter is set up as a procedural. Following this procedural will ensure the Operator is familiarized with all of the mechanical functions of the Dragon A400.

! Caution !



It is important to inspect machine before it is powered up. Handling electrical fittings can cause injury to the technician. Always inspect electrical connections while the machine is powered down, preferably disconnected from power sources.

2.2 Gate

The Gate is located at the front of the Dragon A400. The Gate works in conjunction with the Chuck to support and move material through its cutting process.

2.2.1 Gate Overview

The Gate is important in the operation of the Dragon A400 as it combines with the Chuck to hold the material securely in place during the cutting process. The Dragon A400 comes equipped with one of two different styles of Gate.

Gate Type	Function
Non-Powered Gate	Round, square or rectangle material. Does not support angle or channel
Powered Gate	Round, square, rectangle, angle or channel material. Essential when processing angle or channel.

A Dragon A400 machine equipped with a Non-Powered Gate will not have a C drive motor or ring gear.

A Dragon A400 machine equipped with a Powered Gate will include the C drive motor and Powered Gate Ring Gear.

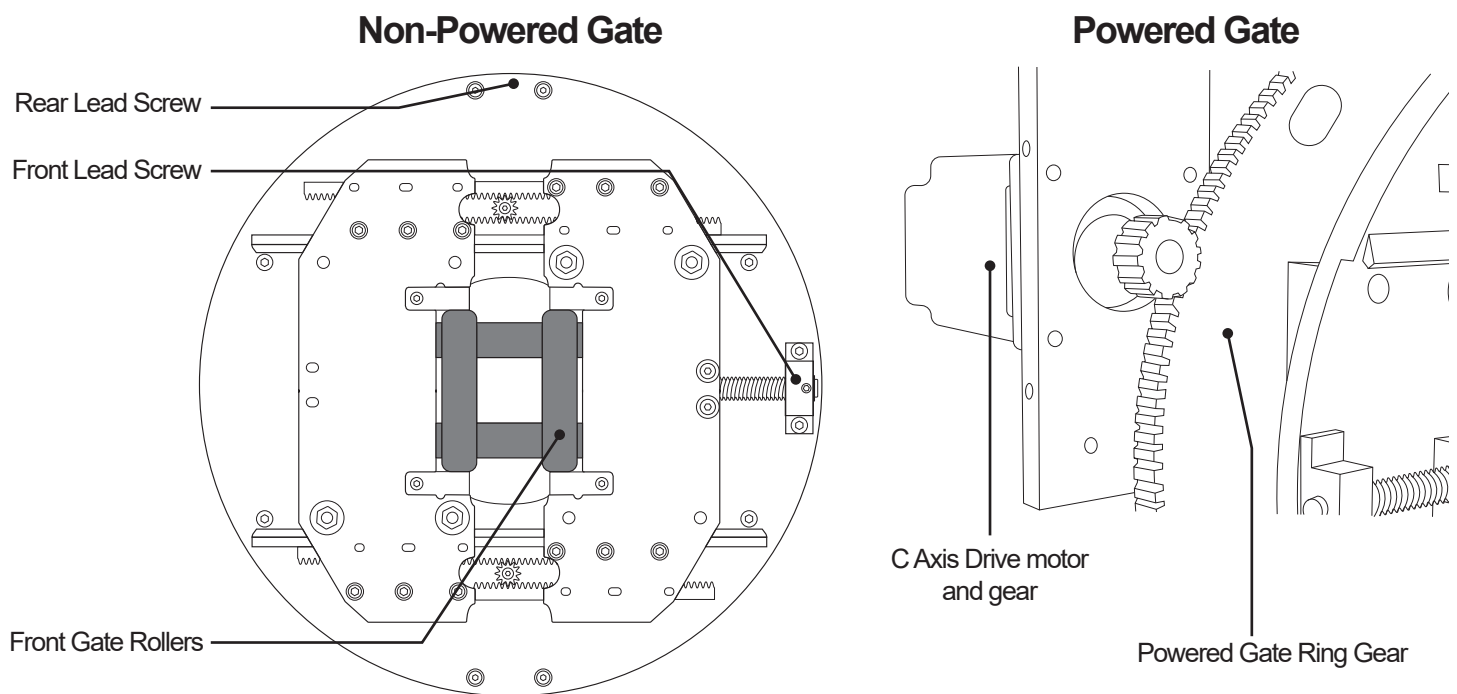

Keeping the Gate clean is key to maintaining optimum performance of the Dragon A400. Refer to Maintenance guidelines for Gate maintenance procedures and intervals.



The eccentric bearing is located at the bottom of the Gate as it is mounted on the machine.



The Gate must be removed from the machine in order to adjust the Gate eccentric bearing.

2.2.2 Gate Eccentric Bearing

The Gate rides on three bearings located on the back face of the assembly. There should be no play in the Gate. The Gate should ride smoothly on its bearings with no binding. If there is play in the Gate, or if it does not ride smoothly, the Gate can be adjusted via its eccentric bearing. There are three bearings on the back of the Gate, only the eccentric bearing is used to adjust the Gate, the remaining two bearings are not adjustable. The Operator should use a $\frac{9}{16}$ in. wrench to adjust the Gate eccentric bearing.

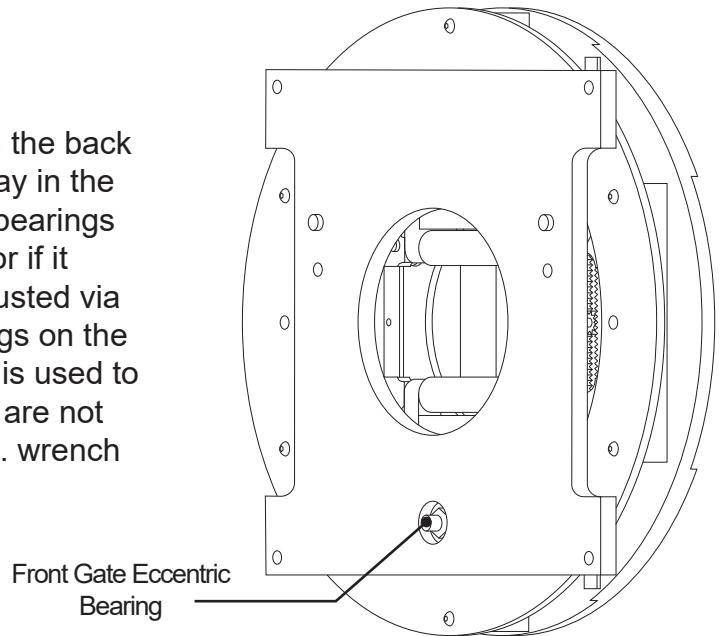

2.2.3 Gate Lead Screws

Lead Screws are used to adjust the opening of the Gate. The Gate uses a front Lead Screw and a rear Lead Screw. Gate Lead Screw operation is accomplished via a $\frac{1}{4}$ in. Allen wrench. The front Lead Screw adjusts the outer Gate opening diameter. The rear Lead Screw adjusts the inner Gate opening diameter. Turning a Gate Lead Screw counterclockwise opens the Gate, turning the Gate Lead Screw clockwise closes the Gate. Gate Lead Screws should operate smoothly with minimal force applied by the Operator and with no binding throughout the travel.



The Dragon A400 is supplied with a $\frac{1}{4}$ in. T-handle Allen wrench.

2.2.4 Gate Adjustment

When loading material, the Gate should be adjusted snug to the material, so the Gate rollers move when turned with a finger but they do not spin freely. Overtightening the Gate on the material can affect the performance of the machine. The Gate should be tightened on the material so it moves freely within the Gate rollers with no play and minimal effort. The Operator should move material back and forth in the Gate to ensure it moves freely and does not bind.



The Gate will only need to be adjusted when changing material types or sizes, or in some cases for removing remnant material.



The Gate may need to be loosened for out-of-round material.

2.2.5 Gate Bearings

The adjustable Gate components use four bearings. The bearings should roll freely without any binding. The adjustable Gate component bearings are set at the factory and require no further adjustment by the Operator.

2.2.6 Gate Rollers

Gate Rollers should spin freely and operate smoothly with minimal play. The Gate Rollers require no adjustment by the Operator.

2.2.7 Gate Clamp

The Gate Clamp is used to lock the Gate into one position. The Gate Clamp is used only for round stock. The Gate Clamp is critical to keeping round stock in position during the cutting operation of the Dragon A400. Always lock the Gate in position with the Gate Lead Screws in the 12 o'clock and 3 o'clock positions.

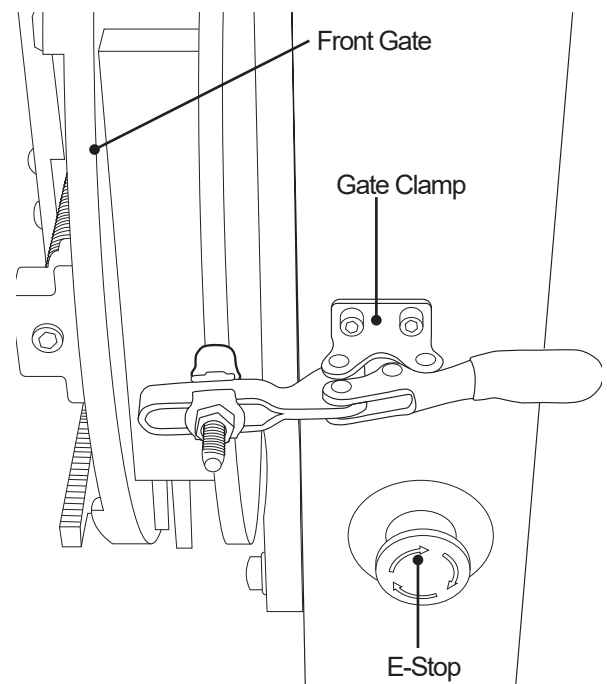



Machines equipped with the Powered Gate do not come equipped with a Gate Clamp.

2.3 Material Support Lift

The Material Support Lift allows the Dragon A400 to process extremely long or thin material. Long Material can sag under its own weight which can affect machine operation and accuracy.

2.3.1 Material Support Lift Overview

Depending on the type and length of stock being cut, it may be necessary to utilize the Material Support Lift to prevent material from sagging. This will ensure accurate cutting of the material. The Material Support Lift can accommodate up to 6-inch OD round stock or 4-inch diameter square stock.

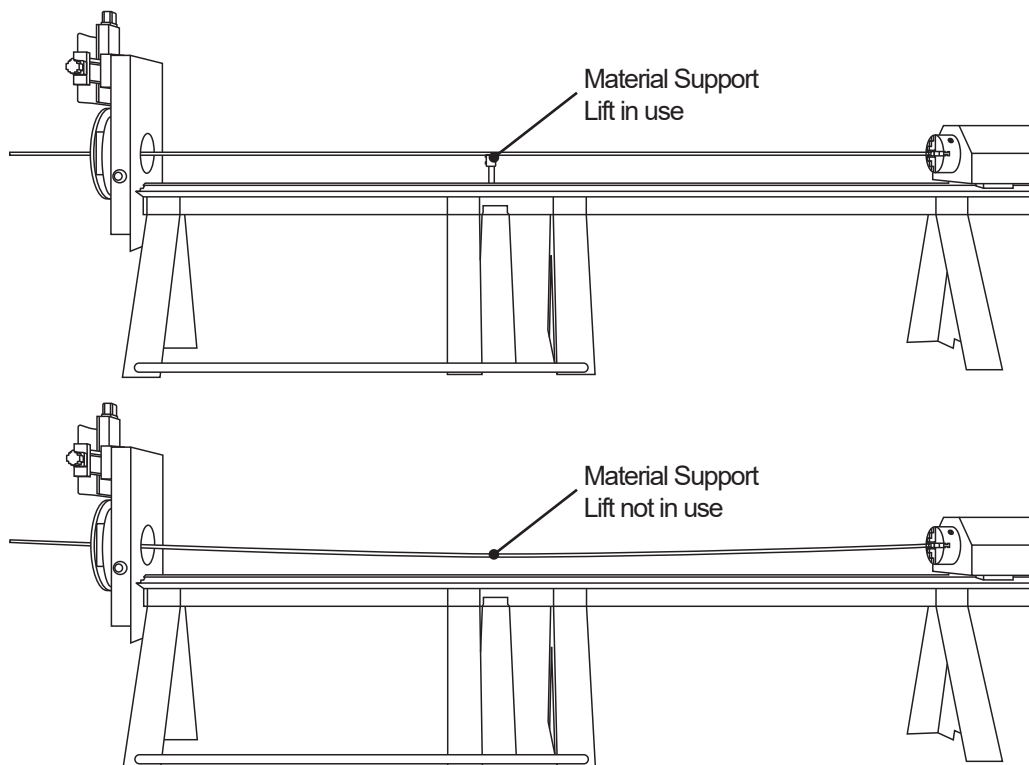

2.3.2 Material Support Lift Operation

The Material Support Lift is powered by the B Axis motor which moves the lift up and down. The rotation of the Material Support Lift is achieved via a pneumatic cylinder. The pneumatic controls for the Material Lift Support are pre-set to 60 psi. However, line pressure going into the machine can affect the speed of operation of the Material Support Lift so some adjustment may be necessary.

2.3.3 Air Cylinder Adjustment

The speed of the Material Support Lift rotation is controlled by a needle valve adjustment screw on either end of the air cylinder. The right side needle valve adjustment controls the inward rotation of the Material Support Lift (toward the Rail) and the left side needle valve adjustment controls the outward rotation of the Material Support Lift (away from the Rail).

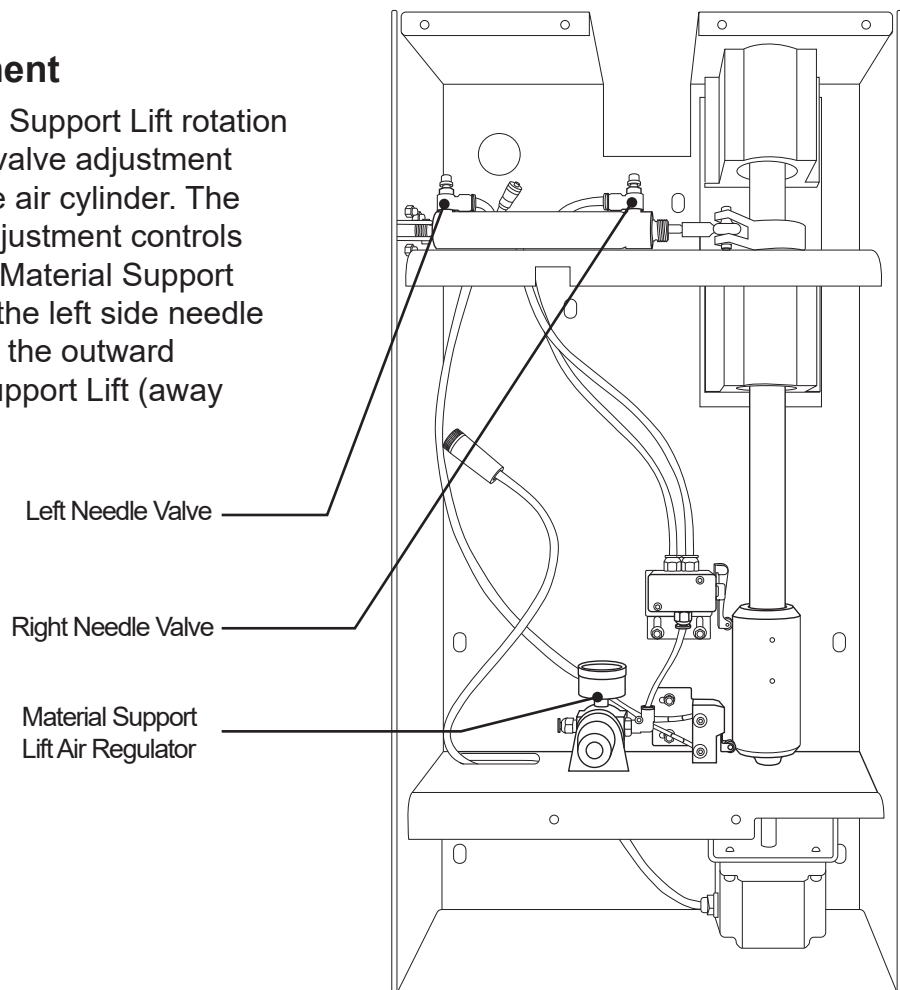

When adjusting the needle valves on the Material Support Lift air cylinder it is best to turn them $\frac{1}{4}$ turn at a time to avoid overadjustment and possible damage to the assembly.

2.4 Toolhead

The Toolhead is located at the front of the Dragon A400. The machine uses the Toolhead to initiate and manipulate tools through the machine's cutting operations.

2.4.1 Toolhead Overview

The Toolhead on the Dragon A400 serves as the tool mount and the vehicle for engaging the tools vertically and horizontally during the machine's operational processes. The Marker, Engraver, Torch and Laser are mounted to the Toolhead. The Toolhead is controlled by the A Axis and Z Axis motors.

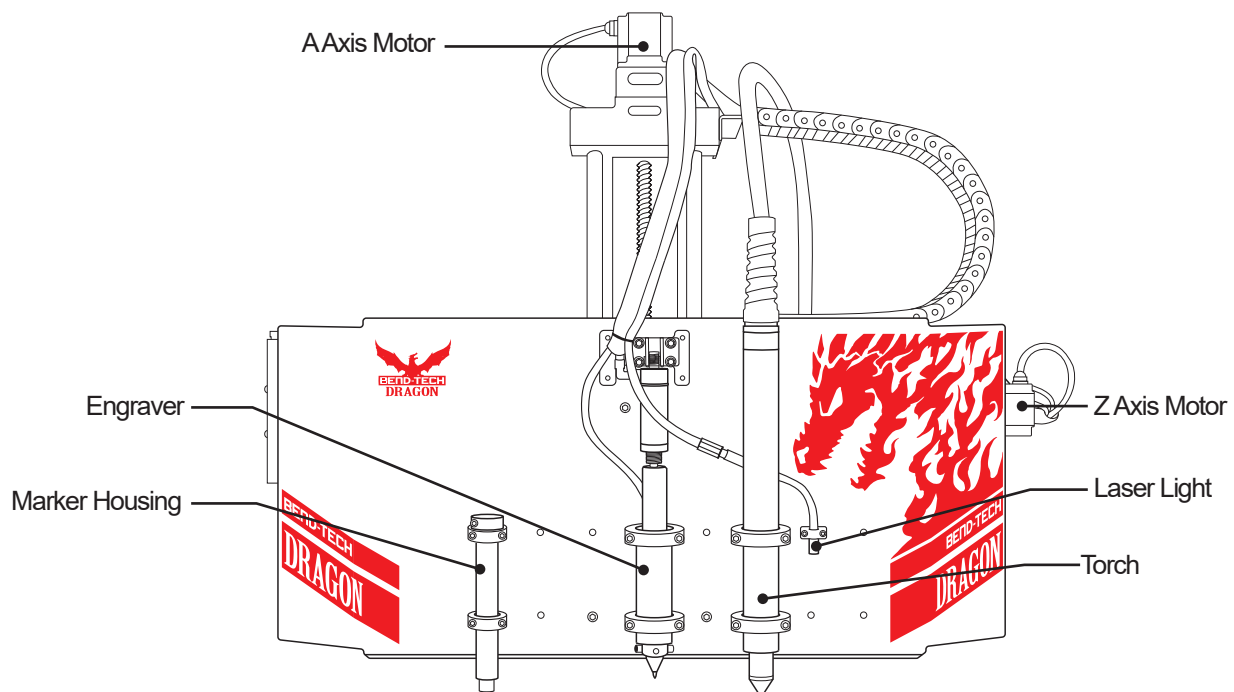

The Marker, Engraver and Torch are mounted left to right on the Toolhead to coincide with the order of operation for each tool.

2.4.2 Toolhead Actuators

The Toolhead is controlled by the A Axis and Z Axis motors. The motors use Actuators to perform vertical and horizontal movement of the Toolhead. The Actuators should be kept clean and free of dust and debris. The Actuators are key to smooth, precise and consistent operation of the Toolhead.

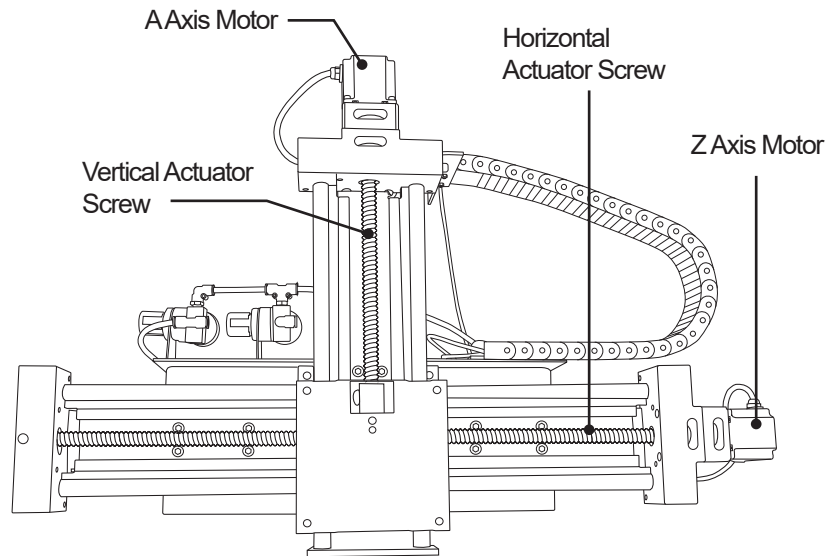

2.4.3 Marker

The Marker Holder is mounted on the left side of the Toolhead. The Marker Holder sits loose in its mount on the Toolhead so it is able to ride over material easily and without damaging the Marker. Depending on the type of Marker being used it may be necessary to modify the Marker body or use a piece of tape to keep the Marker secure in the holder.



Cleanliness of the material will affect Marker life. If a project requires heavy use of the Marker it may benefit the Operator to clean material before loading into the machine. Always keep the marker capped when not in use.

2.4.4 Engraver

The Engraver is mounted in the center of the Toolhead. When the Engraver is engaged, an air cylinder is pressurized and the tool is pushed down to meet the material. The pressurized cylinder, along with the bleeder valve, allows the engraver to ride over contours in the material without damaging the tool.

2.4.5 Engraver Air Regulators

The Engraver is driven by pressurized air. It uses two separate regulators located just behind the Toolhead. The left side regulator controls the Engraver and is pre-set at the Bend-Tech manufacturing facility to 70 PSI.

The right side regulator controls the Engraver air cylinder and is pre-set at the Bend-Tech manufacturing facility to 5-10 PSI.

Engraver Air Pressure Settings	
Engraver	70 PSI
Engraver Actuator Cylinder	5-10 PSI

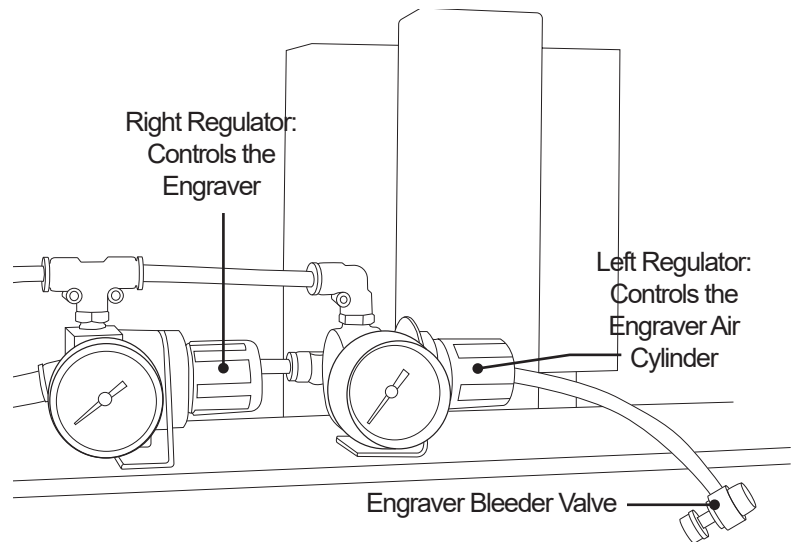

2.4.6 Engraver Bleeder Valve

The Engraver Cylinder and air regulator also use an air bleeder screw. The bleeder screw is located on an air line extension just off the Engraver Air Regulator. When setting Engraver air pressure, ensure the bleeder screw is open all the way.

2.4.7 Torch

Inspection of the Torch is covered in Chapter 1 of the Start-Up and Training Manual Part 3.

2.4.8 Laser

The Laser is used to calibrate the Dragon A400 tools in relation to the material. The Laser is mounted and calibrated at the Bend-Tech manufacturing facility. No adjustment of the Laser is necessary.

! Warning !



The Laser can damage human retinas. Never look directly into the Laser.

2.5 Electrical Components

The Dragon A400 is supplied with numerous customized electrical components. It is important that the Operator familiarize themselves with these components, how they are assembled and routed around the machine and their function(s).

2.5.1 Electrical Components Overview

The Dragon A400 uses various sensors, switches and cables to connect each Axis of the machine to the computer, and to allow the machine to be shut down in case of emergency. Inspecting these electrical components on initial startup as well as on a regular basis will ensure Dragon A400 operation on a long-term basis. The Operator should become familiar with the function and location of all switches and connections on the machine.

2.5.2 Emergency Stops (E-Stops)

There are four Emergency Stop (E-Stop) buttons on the Dragon A400. There is one on either side of the Toolhead, one on the Trolley and one at the Tail. The Operator should check all E-Stops before powering on the machine.

2.5.3 E-Stop Wiring

It is recommended the Operator check the wiring connections on the E-Stop switches to ensure secure connections. While these are secured at the Bend-Tech manufacturing facility, it is possible for these connections to become loose and result in a false E-Stop.

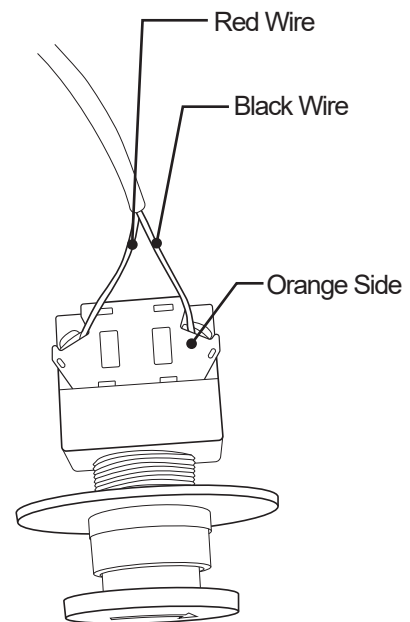

2.5.4 Homing Sensors

The Dragon A400 uses five Homing Sensors; six when the machine is equipped with the Powered Gate. These should be checked for function on initial startup using a metal tool such as the blade of a screwdriver. When touched with a metal tool the sensor will either light up or the sensor light will go out, depending on the location and type of the sensor.

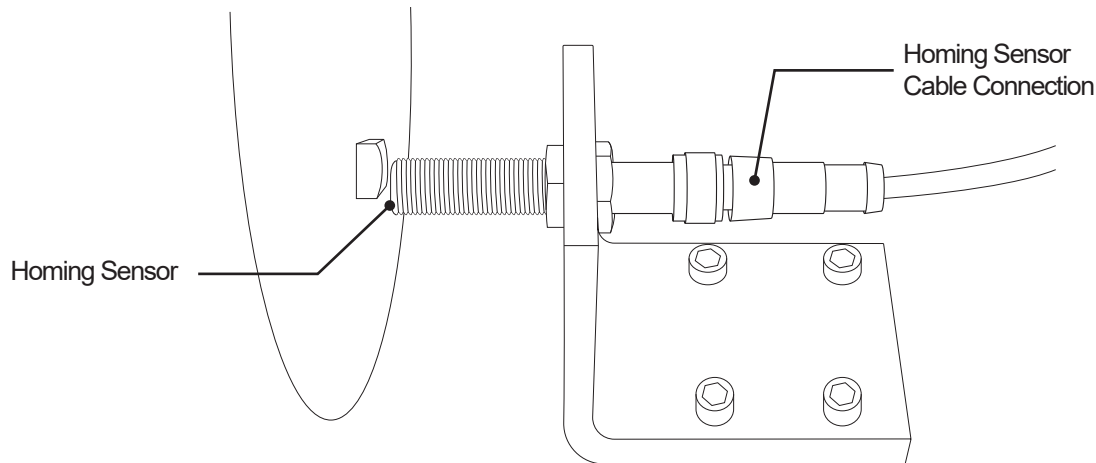

2.5.5 Homing Sensor Designations and Locations

Homing Sensor	Location
X Axis	The X Axis Homing Sensor is located at the end of the beam of the machine. This sensor homes the Trolley on the beam.
Y Axis	The Y Axis Homing Sensor is located at the Left rear of the Trolley, just in front of the Chuck Drive Gear. This sensor homes the Chuck.
Z Axis	The Z Axis Homing Sensor is located on the right-hand side of the Toolhead mount. This sensor homes the Toolhead on its horizontal axis.
A Axis	The A Axis Homing Sensor is located at the top of the Toolhead mount on the front of the machine. The machine uses to the A Axis homing sensor to home the Toolhead on its vertical axis.
B Axis	The B Axis Homing Sensor is located inside the Material Support Lift housing under the Material Support Lift collar sleeve. This sensor homes the Material Support Lift.
C Axis	The Homing Sensor for the C Axis is located on the C Axis Motor mounting bracket on the left side of the front of the machine. This sensor homes the Gate.

2.5.6 Homing Sensor Cable Connections

Homing Sensor Cable Connections should be checked to ensure they are tight and secure. Homing Sensor Cable assembly is performed at the Bend-Tech manufacturing facility.



Do not use tools to tighten cable connectors. Tightening cable connectors with tools can damage them and affect the performance of the machine.

2.6 Motor Cable Connections

Motor Cable Connections achieve connection between Motor Cables, machine Axes and the Control Box.

2.6.1 Motor Cable Connection Overview

The majority of Motor Cable Connections are performed at the Bend-Tech manufacturing facility. Homing Sensor Cable Connections are also performed at the Bend-Tech manufacturing facility. However, it is necessary for the Customer to connect the cables for the X Axis and Y Axis motors when the Dragon A400 is initially assembled. The X Axis and Y Axis connectors are located on the Trolley.

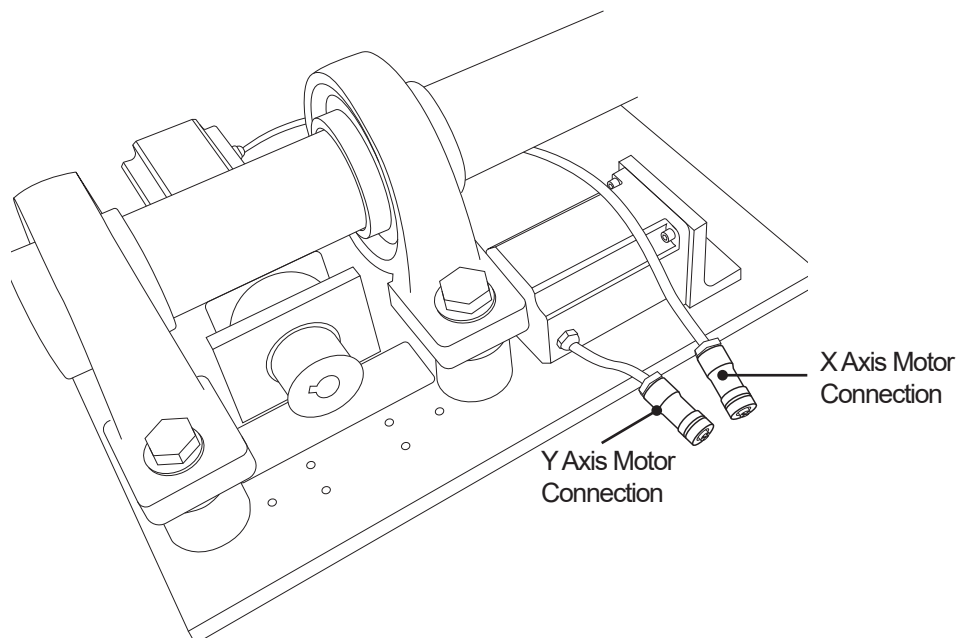

2.7 Hypertherm Unit

The Dragon A400 uses a Hypertherm plasma machine to perform cuts in the material.



If the Customer purchases the Hypertherm unit as part of the Dragon A400 package, Bend-Tech will support the unit and contact Hypertherm regarding issues if necessary.



If the Hypertherm unit is purchased separately it may be up to the Customer to contact Hypertherm with possible technical issues.



Other plasma machines will work with the Dragon A400. Contact Bend-Tech Support for more information.

2.7.1 Hypertherm Overview

Bend-Tech recommends the Hypertherm Powermax45 XP, Powermax65 or Powermax85 for use with the Dragon A400. The Customer can purchase the Dragon A400 supplied with the desired Hypertherm machine or it can be purchased separately.

2.7.2 Hypertherm Cable

The Dragon A400 is supplied with a cable that connects the Hypertherm to the machine's Control Box. This allows the Hypertherm to connect directly to the machine with no customization or modification.

2.7.3 Ground Connection

Bend-Tech recommends using a bolt to connect the ground cable on the Dragon A400 machine to the ground cable of the Hypertherm unit. This requires removing the cable from the alligator clamp on the Hypertherm cable and connecting it to the Dragon A400 cable.

2.7.4 Amperage

Hypertherm units are available for use with the Dragon A400 in 45, 65 and 85 amp versions. The amperage the Customer chooses will depend on the thickness of material being cut as well as the amount of usage the Dragon A400 will see.

2.7.5 Air Supply

The Hypertherm Powermax 45 minimum air supply requirement is 6 cubic feet per minute (cfm) at 90 psi. When cutting thicker material it is possible that the Hypertherm unit will require higher air flow from the air supply. The Customer should ensure the air supply for the Dragon A400 is appropriate to operate the Hypertherm as well as other working aspects of the machine. If connected to a separate air source the Customer should ensure the air source is appropriate to supply the Hypertherm unit.

Air Line and Supply Requirements	
Pressure	90-135 psi
Air Line	3/8 in. minimum
Air Dryer	Yes
Air Filter	Yes
Oil/Oil Vapor Separator	Yes

2.7.6 Gas

The Customer may choose different types of gas for use with their particular Hypertherm unit. Bend-Tech recommends non-flammable gas or shielded gas.

! Danger !



When using the Dragon A400, do not use flammable gas in the plasma cutting process.

2.7.7 Consumables

It is recommended that the Customer have additional consumables on hand when operating the Dragon A400. Worn consumables can result in wider cuts and less precise cuts. Consumables are available through Hypertherm website or via a Hypertherm distributor.

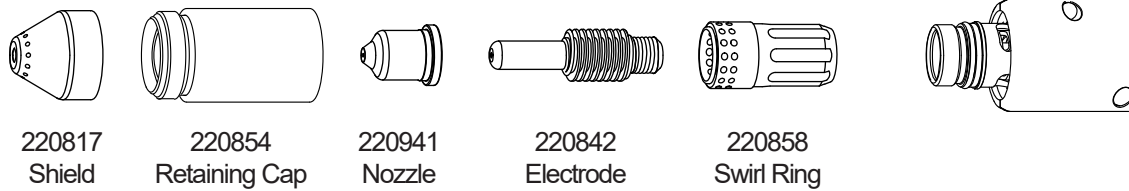

2.7.8 Consumables Part List

45 Amp Consumables			65 Amp Consumables			85 Amp Consumables		
Components	Standard	Fine Cut	Components	Standard	Fine Cut	Components	Standard	Fine Cut
Nozzle	220941	220930	Nozzle	220819	220930	Nozzle	220816	220930
Electrode	220842	220842	Electrode	220842	220842	Electrode	220842	220842
Shield	220817	220948	Shield	220817	220948	Shield	220817	220948
Swirl Ring	220857	220857	Swirl Ring	220857	220857	Swirl Ring	220857	220857
Retaining Cap	220854	220854	Retaining Cap	220854	220854	Retaining Cap	220854	220854



Typically the Operator will only need to replace the nozzle and electrode on the Plasma torch.



An air filter and air dryer on the Hypertherm air source can increase Torch consumable service life.

Machine Control Startup

3.1 Overview of Software Operation

The Dragon A400 is shipped with a new Dell Inspiron computer preloaded with Bend-Tech 7X Software, as well as Newfangled Solutions Mach3 six-axis CNC controller software package. Mach3 is the machine driving software for the Dragon A400. Bend-Tech software uses Mach3 to communicate with the Control Box on the Dragon A400 to control all the operations of the machine.

Bend-Tech 7X software is the user interface for operating the Dragon A400. The Operator will interface with Mach3 software on a limited basis during machine operation. Dragon A400 operation is performed primarily through the Bend-Tech operating system

3.1.1 Ethernet Connection

The Ethernet Connection is how the Dragon A400 computer communicates with the machine. The Ethernet cable should be connected directly from the Ethernet connection on the Control Box to the Ethernet connection on the computer. Connect the computer to the internet router via wifi.



It is always best to route the Ethernet cable away from other electrical cables. Any interference with, or interruption of, the ethernet signal can affect the operation of the Dragon A400 machine.



It is important to route the Ethernet cable away from the Torch and motor cables. Torch and motor cables will create significant electrical interference with the Ethernet cable and can affect the signal between the computer and the machine.



Do not connect the Dragon A400 computer to the machine via the router, always connect the Ethernet port directly from the machine's Ethernet port to the computer Ethernet port.



Do not connect the Ethernet cord to the USB port of the Dragon A400 computer, always connect the Ethernet port directly from the machine's Ethernet port to the computer Ethernet port.

3.2 Booting Up The Dragon A400

Booting up the Dragon A400 requires following a specific procedure. Following this procedure in the proper order will ensure the Dragon A400 is up and running as quickly as possible. Failure to follow the procedure in the proper order can affect machine operation and lead to unnecessary down time.

3.2.1 Power On Computer

Power on the Computer by pressing the power button located on the front of the unit. Make sure the power cord is plugged in to a reliable power source. It is highly recommended that electronics such as the Dell Inspiron be protected from power surges by surge protector. This will insure that, should there be power fluctuations in the building, the Dragon A400 control software system will be protected.

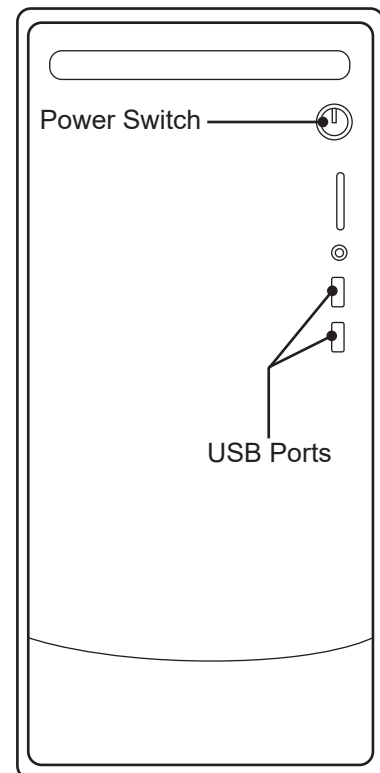

! Caution !



Do not open Mach 3 or Bend-Tech software at this time.

3.3 Power On Control Box

The Operator should have thoroughly inspected the Control Box according to procedure in Chapter 1. The Operator should have thoroughly inspected all electrical connections, components and operation according to procedure in Chapter 2. Following these procedures ensures the Dragon A400 electrical control system is set up properly and ready for operation.

3.3.1 Main Power Switch

On the Dragon A400 control box, flip the Main Power Switch to ON (when ON the side of the rocker switch with the “-” symbol will be depressed).

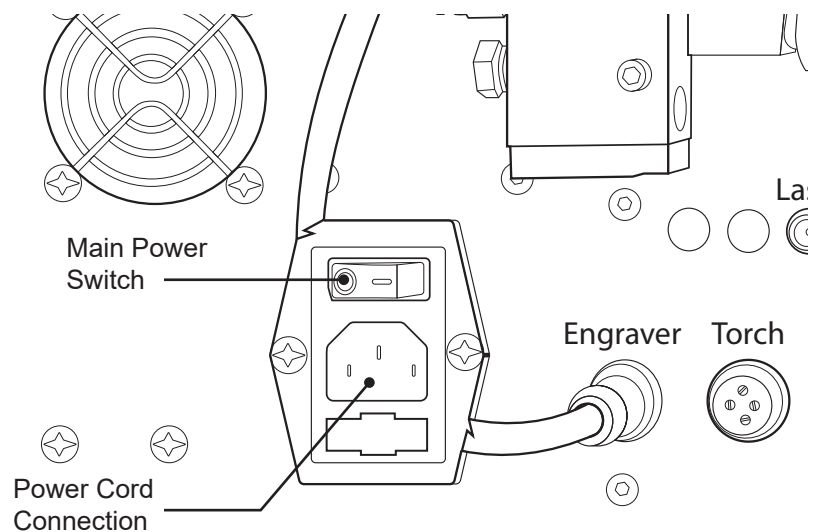

3.3.2 Green Power Button

With the Main Power Switch ON, press the Green Power Button. It will light up.



If the Green Power Button will not stay lit it is likely due to an E-Stop that has been triggered. In this case check all E-Stop buttons.

3.3.3 Launch Bend-Tech 7X

On the home screen, click Bend-Tech 7X icon to launch the software program. An interface will open showing options to launch Dragon CAD, Dragon CAM and Dragon CAD + Dragon CAM. The Dragon A400 is operated fully with the Dragon CAM software. Dragon CAD software is used to design assemblies for production.

3.3.4 Dragon A400 Software Color Designations

Software	Color	Function
Dragon CAD	Blue	Assembly Design
Dragon CAM	Orange	Dragon A400 Operation
Dragon CAD + CAM	Both Screens Open	Assembly Design and Dragon A400 Integration

3.3.5 Bend-Tech Launcher

With the Bend Tech 7X program open, click on Dragon CAM to begin operation of the Dragon A400.

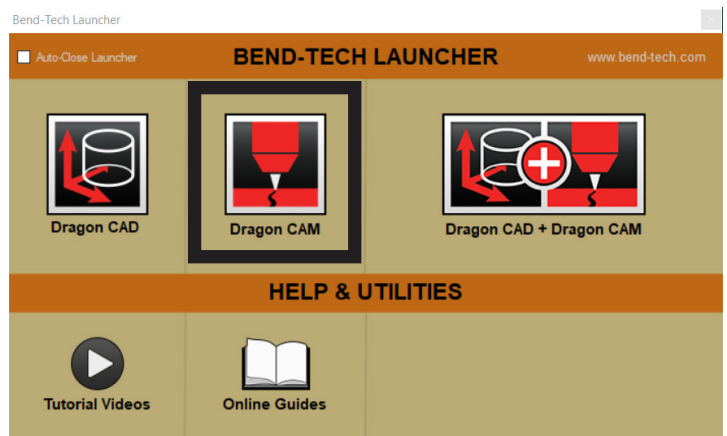

3.3.6 Machine Control



At the top of the screen, click Machine Control.

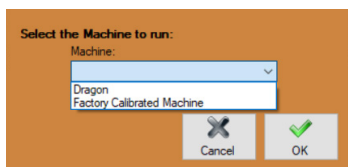

Click the down arrow next to the Machine Selection window. Select the Dragon A400 name the Operator created in 3.3.6.

Click OK. Mach3 software will open at this time.



In some cases, if there is only one machine entered in the Machine Library, the program may go straight to Mach3 and not present a Machine Selection window after clicking Machine Control.



If Mach3 does not connect properly repeat Power On Dragon A400 Control Box procedure beginning at Section 3.3.

3.3.7 Mach3 Machine Control

Mach3 CNC software control interface will appear. The Operator will primarily work in the Bend-Tech Machine Control interface when operating the Dragon A400.

Machine Control interface

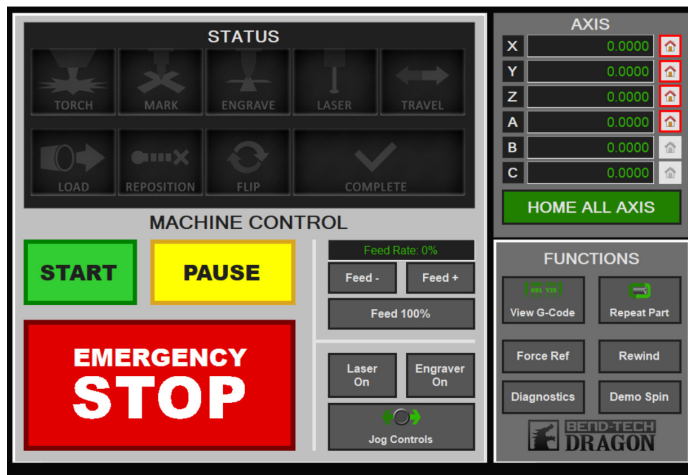

Mach3 CNC Machine Control interface

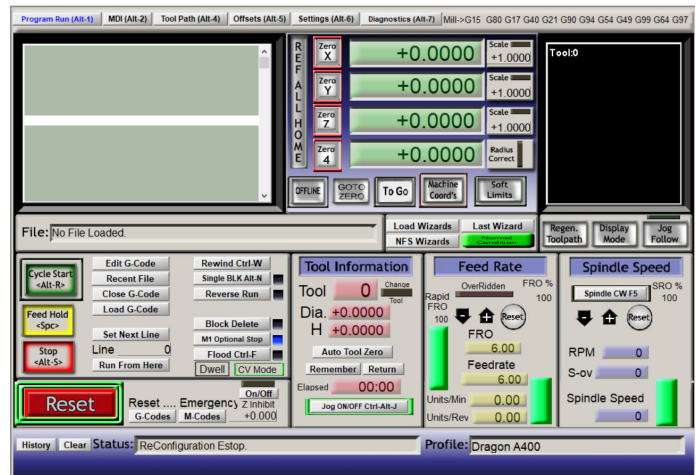

3.3.8 Enable Machine

Upon initial startup, the Machine Control screen will be mostly grayed-out and a red “Machine Disabled - Press Here To Enable Machine” window will be flashing.

Click on “Machine Disabled - Press Here To Enable Machine.” The Dragon A400 is now enabled.

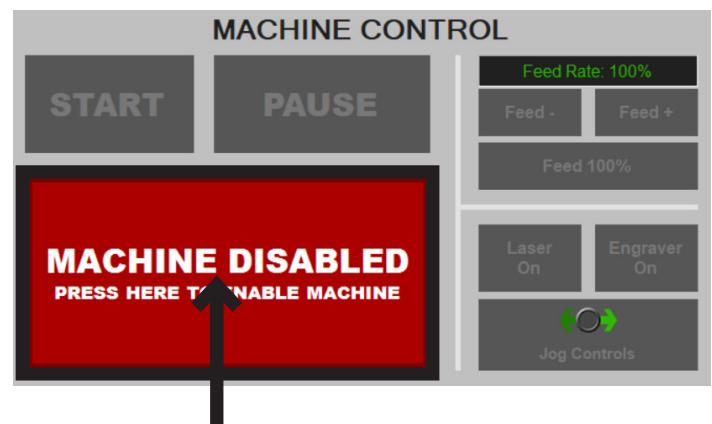

3.4 Jog Controls System Check

Upon initial startup it is important to verify all motors are working as intended. The Operator can use the Jog Controls feature to determine proper machine operation.



3.4.1 Open Jog Controls

At the bottom center of the Machine Control screen, click Jog Controls to open the Jog Controls interface screen. Jog controls are referenced to their respective motor (see Motor Location and Operation Index table 3.4.2).

3.4.2 Motor Location and Operation Index

Jog Control	Operation
X++	Trolley Forward
X-	Trolley Backward
Y++	Chuck Clockwise
Y-	Chuck Counter-Clockwise
A++	Tool Changer Down
A-	Tool Changer Up
Z++	Tool Changer Left
Z-	Tool Changer Right
B++	Material Support Lifter Up
B-	Material Support Lifter Down
C++	Powered Gate Clockwise
C-	Powered Gate Counter-Clockwise

3.4.3 Jogging the Machine

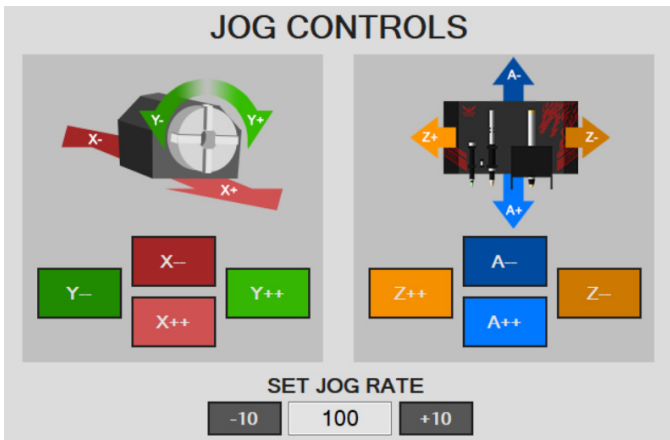

With the Jog Controls screen open the Operator can jog the Dragon A400 to observe that all controls are in working order.

! Caution !



Avoid jogging the machine to the limits of its operation.

3.5 Homing The Machine

Before beginning operations with the Dragon A400, the machine must determine Home for all of its operating Axes. This allows the machine to operate efficiently and within its operational parameters.

3.5.1 Homing An AXIS

The AXIS feature on the Machine Controls screen allows the operator to Home each Axis of the Dragon A400. Each Axis is labeled according to its corresponding moving feature as defined in the Axis Definition Table 3.5.2.

To home an individual Axis the Operator can click the House icon corresponding to the Axis on the right hand side of the AXIS feature.





Do not Home any Axes at this time.

3.5.2 Axis Definition Table

Axis	Definition
X	Trolley
Y	Chuck
Z	Tool Changer Left/Right
A	Tool Changer Up/Down
B	Material Support Lifter
C	Powered Gate

3.5.3 Jog The Trolley

To speed up the Homing procedure the Operator can jog the Trolley near the end of the Rail, so it has less distance to travel to contact the X Axis homing switch.



All the Axes move in a negative direction to Home.

! Caution !



When jogging the Trolley to the end of the Rail allow it time to decelerate. If the Trolley contacts the end of the Rail the Operator will see a Machine Disabled signal. This is a safety feature designed to protect the Dragon A400 from being damaged. The Operator will need to click Enable Machine to resume machine operation.

3.5.4 Home All Axis



The Operator has the ability to home each feature individually or choose HOME ALL AXIS. Upon initial machine startup the operator should choose HOME ALL AXIS and allow the machine to complete this action.

Click HOME ALL AXIS. This procedure will take a few minutes. The Operator should observe the procedure to ensure all Axes are safely homed by the program with no interference.



House icons will turn green when the Axis is homed.

3.6 Hypertherm

Powering on the Hypertherm plasma cutting machine is the last step in preparing the Dragon A400 to run. The Operator should have set up and connected the Hypertherm according to the procedures outlined in Chapter 2.7.



Ensure the Hypertherm unit is set to cut the type of material or to perform the cutting procedure as intended. The Hypertherm will go to default PSI settings. However, the Operator will need to adjust amperage as necessary.



The controls for the Hypertherm Powermax45 and Powermax65/Powermax85 are different. The Operator should familiarize themselves with the controls of the Hypertherm unit using the Operator's Manual found in the box.

3.6.1 Hypertherm Power Switch

The power switch for the Hypertherm Powermax45 is located on the front of the machine. It is a rocker switch. Press "I" to power on the unit. The power switch for the Hypertherm Powermax65 and Powermax85 is located on the back of the machine. Turn it clockwise to power on the unit.

! Caution !



Ensure the Hypertherm ground clamp is connected to the Dragon A400 ground wire.



Ensure the air supply is connected to the Hypertherm.

3.6.2 Hypertherm Cut Type

The Standard Cutting mode is the most common setting that will be used with the Dragon A400. On the Hypertherm this is typically the second mode down (clockwise) on the cutting mode switch.



Always refer to the Bend-Tech Plasma Cutting Guide for the most accurate setting information.

3.6.3 Hypertherm Air Supply

The Hypertherm Powermax45 minimum air supply requirement is 6 cubic feet per minute (cfm) at 90 psi. When cutting thicker material it is possible that the Hypertherm unit will require higher air flow from the air supply. The Customer should ensure the air supply for the Dragon A400 is appropriate to operate the Hypertherm as well as other working aspects of the machine. If connected to a separate air source the Customer should ensure the air source is appropriate to supply the Hypertherm unit. See section 2.7.4 for Hypertherm air supply requirements.

3.6.4 Hypertherm PSI Settings

The Hypertherm unit will be pre-set to a default PSI. This is the recommended starting point for cutting operations on the Dragon A400.

3.6.5 Hypertherm Cut Settings

As a rule, speed and amperage settings should be on the low end of what Hypertherm recommends for a given material. For any given cut, Bend-Tech recommends dividing the recommended Hypertherm feed rate in half as a starting point of operation.

The Dragon A400 machine parameters are now set.

Attention

After completing Start-up and Training Manual Part 2, please proceed to Start-up and Training Manual Part 3.

Bend-Tech, LLC

729 Prospect Ave. Osceola, WI 54020
1-651-257-8715

sales@bend-tech.com
www.bend-tech.com