

BEND-TECH DRAGON A400

Startup Manual Part 1: Safety and Maintenance

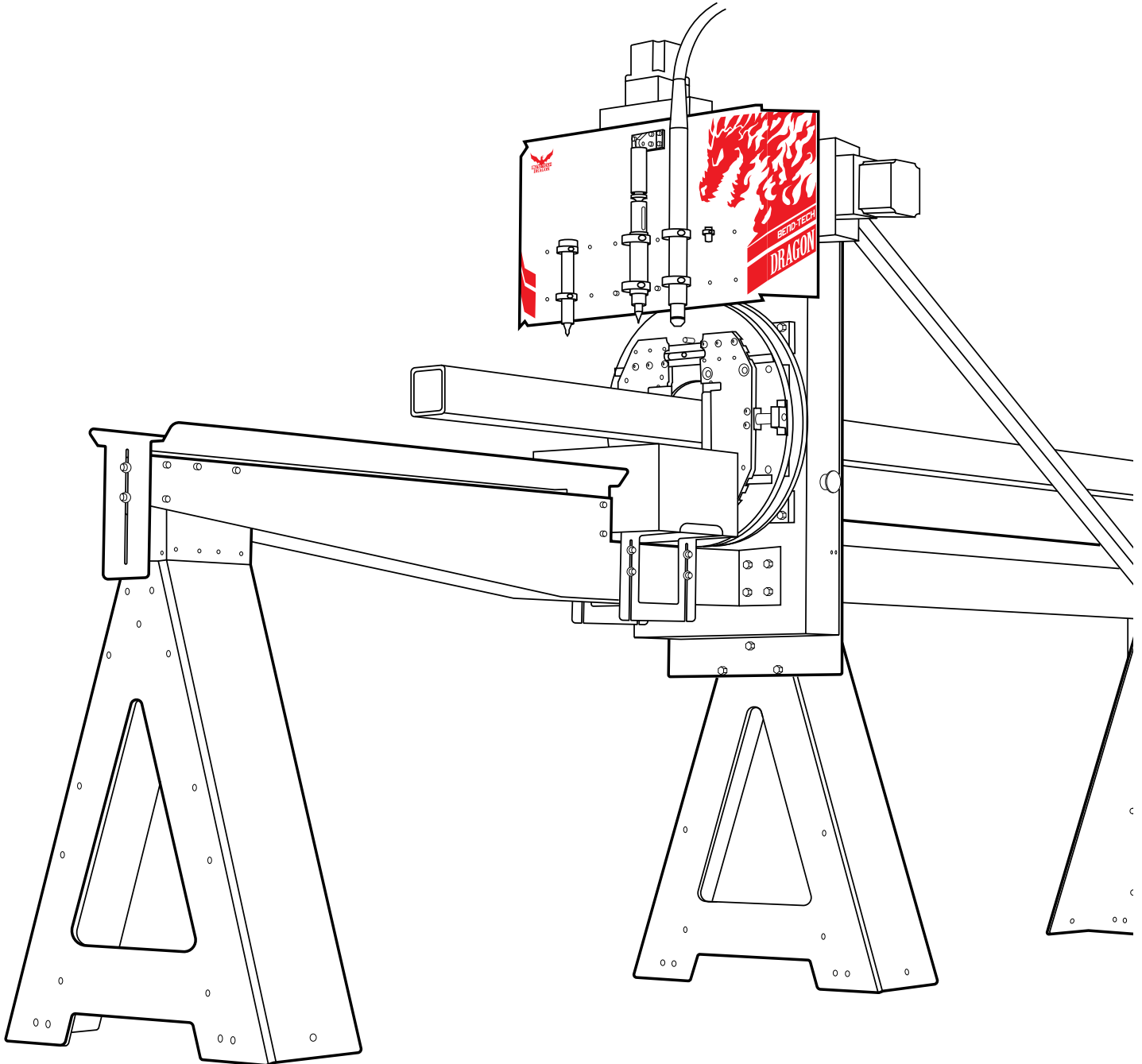

©2022 Bend-Tech LLC

All rights reserved. The information in this manual is subject to change without notice. Bend-Tech LLC strives to produce the most complete and accurate information regarding its products. We are constantly working to improve and advance our products to increase performance, user satisfaction and experience. Bend-Tech LLC assumes no responsibility for errors or omissions regarding this manual. Bend-Tech LLC assumes no liability for damages resulting from the use of the information contained in this publication.

Dragon A400

Startup and Training Manual Revision 7

English
Original Instructions

October 2022

Bend-Tech LLC
729 Prospect Ave.
Osceola, WI 54020 USA

(651) 257-8715
www.bend-tech.com
support@bend-tech.com

Contents

Contents iv
Limited Warranty vi
Customer Satisfaction Commitment.vii
Customer Service.vii
Alertsviii
Glossary. x

01

Safety 13

1.1 General Safety Notes 13
1.2 Safety Procedures 14
 1.2.1 Personal Protective Equipment (PPE) 14
 1.2.2 Machine Safety Labels 14
1.3 Recommended PPE for Operating the Dragon A400 16
 1.3.1 Eye Protection 16
 1.3.2 Footwear 16
 1.3.3 Heat-Resistant Gloves. 16
 1.3.4 Hearing Protection. 17
 1.3.5 Breather Mask or Ventilation System 17
1.4 Operational Safety 18
 1.4.1 Guards. 18
 1.4.2 Machine Inspection 18
 1.4.3 Machine Operational Movement. 18
 1.4.4 Material Securing. 19
1.5 Pinch Points 19
1.6 Emergency Stops (E-Stops). 20
 1.6.1 E-Stop Overview 20
 1.6.2 Control Screen E-Stop. 21
 1.6.3 Re-Home after an Emergency Stop 21

1.7 Electrical Servicing. 21
 1.7.1 Power Down Before Servicing. 21
1.8 Material Weight 22
 1.8.1 Weight Limit. 22
1.9 Material Length 22
 1.9.1 Material Support Lift. 22
1.10 Modifications To The Machine 22
 1.10.1 Unauthorized Modifications . . 22
 1.10.2 Factory Parts Kits and Updates 23
1.11 Other Safety Information 23
1.12 More Information 23
1.13 Recommended Safety Guidelines . 24

02

Maintenance 25

2.1 Dragon A400 Maintenance Overview 25
2.2 Daily Maintenance 25
 2.2.1 Clean the Gate. 25
 2.2.2 Clean the Support Beam 26
 2.2.3 Clean the Rack 26
 2.2.4 Check the Coolant Level 26
 2.2.5 Clear the Part Catcher. 26
 2.2.6 Check the Air Pressure 26
 2.2.7 Clean the Work Area 26
 2.2.8 Check the Plasma System. 26
2.3 Weekly or Every 40 Hours 26
 2.3.1 Clean Grease and Oil Buildup . 26
 2.3.2 Check Electronic Connections. 27
 2.3.3 Clean Chuck and Trolley 27
 2.3.4 Lubricate the Gear Rack 27
 2.3.5 Actuators and Lead Screws . . . 27

- 2.3.6 Clean and Re-lubricate the Roller Bearings 27
- 2.4 Monthly or 150 Hours 27
 - 2.4.1 Check the Fasteners 27
 - 2.4.2 Clean and Fill the Material Cooling System Reservoir 27
 - 2.4.3 Check the Eccentric Bearings . . 27
 - 2.4.4 Check the Emergency Stops . . 28
 - 2.4.5 Clean and Lubricate the Racks 28
 - 2.4.6 Check Backlash 28
- 2.5 Quarterly or 500 Hours 28
 - 2.5.1 Clean Coolant Screens 28
 - 2.5.2 Grease Pillow Block Bearings . 28
 - 2.5.3 Comprehensive Cleaning 28
- 2.6 Bi-Annually or 1000 Hours 28
 - 2.6.1 Clean the Chuck 28
 - 2.6.2 Check Level and Straightness . 28
- 2.7 Annually or 2000 Hours 29
 - 2.7.1 Check Rack Spacing 29

Limited Warranty

Covering Bend-Tech Dragon

Bend-Tech LLC provides a limited warranty on all new Dragon machines that are manufactured directly or under license by Bend-Tech LLC, and sold by Bend-Tech LLC or its approved distributors.

Warranty Coverage

Each Bend-Tech Dragon machine is warranted by the manufacturer against defects in material workmanship for 12-months. The warranty period commences upon delivery of the Dragon machine to the customer's facility.

Repair or Replacement Only

The Manufacturer's sole liability, and the Customer's exclusive remedy under this warranty shall be limited to repairing or replacing the defective part. Repair or replacement of parts is at the sole discretion of the manufacturer. The Customer is responsible for warranty parts installation. Bend-Tech does not provide warranty service labor.

Limits

This warranty does not cover components subject to wear due to normal use of the machine such as belts, lights, tooling etc. This warranty is void if Bend-Tech LLC has determined any failure is the result of mishandling, abuse, misuse, improper installation, improper storage, improper maintenance or unauthorized modification of the machine. The warranty does not cover damage due to natural disasters, fire, flood or other external factors. The warranty may become void or limited in the event that hardware changes or adaptations are made to the machine.

Software

The standard 2-year software maintenance plan is included with the purchase of a Dragon. Before the 2-year maintenance plan has expired, the customer may purchase an extended maintenance plan. The maintenance plan and extended maintenance plans will ensure the customer always has the newest version of Dragon Software. The maintenance plan is critical to keeping Dragon software updated with the newest capabilities possible, and is critical to the servicing of the machine. Bend-Tech LLC will contact the Customer regarding updates to the maintenance plan within 1-month of expiration. Contact Bend-Tech Support to ensure software is up to date: support@bend-tech.com.

Customer Satisfaction Commitment

Congratulations on your purchase of the world's best CNC plasma tube and pipe cutting machine, the Bend-Tech Dragon. Bend-Tech LLC places great pride in customer satisfaction and it is our promise to offer you the best support available for your Dragon. We recognize that our support is a key factor in your success.

Contact Us

Bend-Tech's hours of operation are Monday - Friday, 8:00 am - 5:00 pm EST. The Bend-Tech support team and sales team are always available during our hours of operation.

Phone: 651-257-8715

Email: Sales team: sales@bend-tech.com
Support team: support@bend-tech.com

Address: Bend-Tech, 729 Prospect Ave., Osceola, WI 54020, U.S.A..

Customer Service

Comments, questions, or concerns regarding the Dragon Machine, this manual, or the Bend-Tech Software can be directed to Bend-Tech sales and service representatives at the above contact information. Check out the following links for more information regarding Dragon Machines and Bend-Tech Software.

Website, Socials, and Online Resources

- <http://www.bend-tech.com>
- <https://www.facebook.com/2020ssi>
- https://www.instagram.com/bend_tech
- <https://www.youtube.com/bendtech2020>
- <http://www.bend-tech.com/wiki7>

Alerts

Bend-Tech manuals use specific callouts to highlight important information. Each style of callout pertains to specific types of information being given. The machine operator should familiarize themselves with the following definitions and examples of each type.

Definitions & Examples

Danger

! Danger !



Danger indicates a serious condition that could cause severe injury or death to the operator or bystanders if the instructions are not followed.

Warning

! Warning !



A Warning indicates there is a possibility for minor injury if the instructions are not followed correctly.

Caution

! Caution !



Caution warns the operator that minor injury or machine damage could occur if instructions are not followed. It could also mean that not following directions could affect the overall procedure being performed.

Important Alerts

Important

Important notes give clarification or focuses on information that is critical or unique to an operation.

Notes and Tips

Note or Tip

Notes and tips give additional helpful information for operating the Dragon machine or Dragon software. They are meant for supplemental information and not information that is critical for operating procedures.

Glossary

Axis

A fixed reference line.

Beak

The front assembly that includes the Parts Catcher and Parts Bin/Bucket. The Material Coolant System replaces most of the Beak when installed.

CAD

Computer Aided Design. Modeling or design software for creating parts, components, or whole assemblies. Used for manufacturing or similar industries. Can be 2D or 3D design.

CAM

Computer Aided Manufacturing or Machining. Using the computer to assist in operating machines by converting CAD models into G-Code that the machine recognizes.

Chuck

Secures and rotates the material. Part of the Trolley. Also referred to as the Y-Axis.

Control Box

Contains the motor drivers and other electrical components that allows the Dragon CAM software to control the Dragon machines.

Deadzone

The space between the Chuck and the Laser Light position when the Chuck is all the way forward.

Emergency Stop

Abbreviated E-STOP. A button which shuts down machine operations. Four are located on the machine and one is part of Machine Control.

Gate

The adjustable mechanism that holds the material in place at the Head of the Machine.

Head

The machine assembly that makes up the front end of the machine.

Limit Switch

The switch that operates as an automatic control to prevent a mechanism or process from going beyond a prescribed limit.

Load Position

The position the machine enters after clicking START on machine control the first time after starting a cutting project. This allows the operator to more easily load the designated material into the machine.

Mach3

The driving software behind Machine Control. Required for the machine to operate.

Machine Control

The computer interface that controls the machine operations. Used by the operator when running projects.

Material Coolant System

The system that transports coolant through the material during cutting operations.

Material Support Lift

The mechanism that supports the material during cutting. Sometimes referred to as the Lifter.

Parts Catcher

The Parts Catcher is placed at the front of the machine to catch parts as they are cut.

Support Beam

Forms the backbone of the machine. Comprised of Aluminum Beams and Steel Rails.

Tail

The machine assembly that makes up the far end of the machine.

Task Menu

The first menu that opens upon starting the Dragon Software or the Bend-Tech software. From this menu various tasks can be started, such as part designing, importing, library access, etc.

Toolhead

The machine component that the tools are attached too. Maneuvers the tools into position with the A and Z axes.

Trolley

The machine component that includes the Chuck. Travels along the Support Beam on the X-Axis.

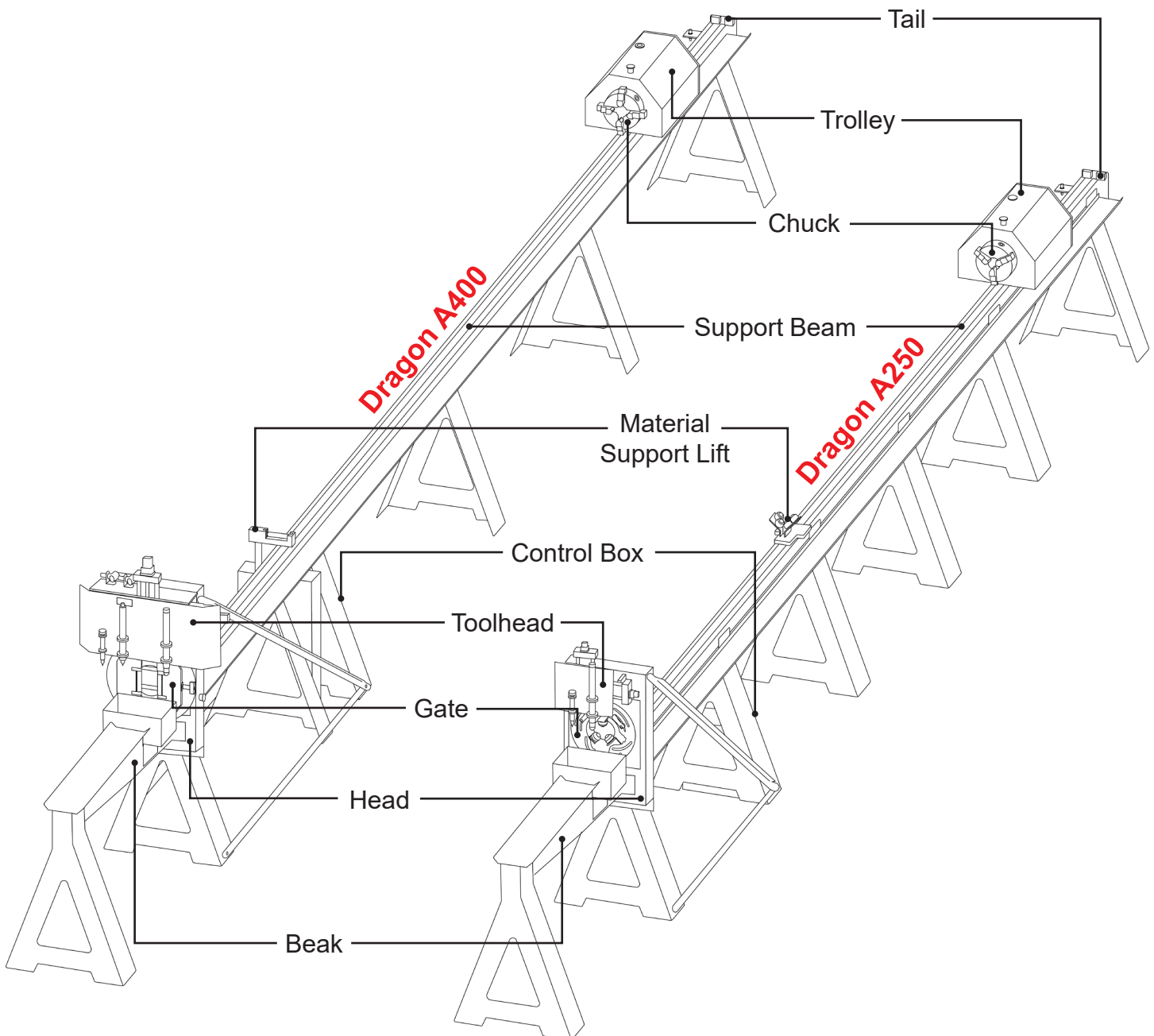

01

Safety

1.1 General Safety Notes

Read all warnings, cautions, and instructions before operating the Dragon machine.

Each company has different procedures. Always act in accordance with Environmental Health & Safety (EHS) standards set in place regarding the facility in which the Dragon A400 is being operated.

Follow basic safety precautions to reduce the risk of injury or mechanical damage. CNC metal working machines such as the Bend-Tech Dragon machines introduce hazards to the workplace. It is the responsibility of the operator to take appropriate safety measures regarding the potential hazards of this machine, and not the responsibility of Bend-Tech, LLC.

Maintaining a clean machine is important during normal use as well as prior to and after servicing the machine. Cleaning procedures may require Personal Protective Equipment (PPE) beyond the scope of daily operation procedures of the machine.

Read all parts of the Startup manual in their entirety to ensure safe and efficient operation of the Dragon A400 machine.

This manual is a reference guide for the Dragon A400 and is not a comprehensive source of operating or training information. A complete training course and support can be requested from Bend-Tech, LLC, www.bend-tech.com.

! Caution !



The Dragon A400 should only be operated by authorized and trained personnel. The operator should always act in accordance with the Dragon A400 Startup safety procedures and machine instructions for safe operation of this machine. Failure to follow these guidelines may pose a hazard to personnel and the machine.

1.2 Safety Procedures

1.2.1 Personal Protective Equipment (PPE)













Metalworking and metalworking operations can be dangerous. Using the proper PPE is important to avoid injuries that can result from sparks, heat, noise, smoke and vapor, dropped objects, and ultraviolet light. Consult local safety codes before operating the machine. Before working on or near the machine, it is important to read this manual and fully understand the safe operation of the machine. Contact Bend-Tech with any questions or concerns regarding the safe operation of the Dragon A400.

It is recommended that the operator read the plasma torch operator’s manual and become familiar with the hazards of working with the torch before operating it in conjunction with the Dragon.



1.2.2 Machine Safety Labels

The following Safety Labels are found on the Dragon A400.

Back Plate

General	PPE Info	Plasma Cutter
 <p>ALL OPERATORS MUST READ ALL SAFETY GUIDES AND BE KNOWLEDGEABLE IN SAFE USE OF THE MACHINE BEFORE OPERATING THE MACHINE.</p> <p>FAILURE TO DO SO CAN RESULT IN DAMAGE TO MACHINE, SERIOUS INJURY, OR DEATH.</p>	<p> HEAT PROTECTION GLOVES Cut parts are hot and cause burns.</p> <p> WEAR SAFETY GLASSES Plasma sparks, metal processing can create harmful debris for the eyes.</p> <p> WEAR PROTECTIVE SHADES Plasma arc rays can burn eyes.</p> <p> HEARING PROTECTION Plasma cutting and engraving can exceed acceptable noise levels and can damage hearing.</p> <p> STEEL TOED BOOTS Heavy metal can cause feet injury.</p>	<p> MUST READ PLASMA UNIT'S SAFETY AND COMPLIANCE MANUAL BEFORE OPERATING.</p> <p> ELECTRIC SHOCK</p> <p> FIRE OR EXPLOSION HAZARD</p> <p> TOXIC FUMES CAN CAUSE INJURY OR DEATH</p> <p> PLASMA ARC CAN CAUSE INJURY AND BURNS</p> <p> ARC RAYS CAN BURN EYES AND SKIN</p>





Toolhead

WARNING	
	<p>PLASMA CUTTER REFER TO YOUR PLASMA UNIT'S SAFETY & COMPLIANCE MANUAL.</p>
	<p>LASER RADIATION LASER POINTER'S BEAM CAN RESULT IN SERIOUS EYE INJURY. AVOID EYE EXPOSURE.</p>
	<p>PINCH POINTS STAY CLEAR OF MOVING PARTS.</p>

Gate

WARNING	
	<p>PINCH POINT MOVING PARTS. KEEP CLEAR DURING OPERATION.</p>
	<p>NO LOOSE ITEMS OR CLOTHING DO NOT WEAR LOOSE CLOTHING, JEWELRY, OR LONG HAIR.</p>
	<p>CRUSH HAZARD STAY CLEAR OF MOVING OR FALLING MATERIAL.</p>
	<p>HOT MATERIAL PLASMA CUT METAL WILL BE HOT.</p>

Trolley

WARNING			
	<p>PINCH POINTS MOVING PARTS CAN CRUSH OR CUT. KEEP CLEAR.</p>		<p>NO LOOSE ITEMS OR CLOTHING DO NOT WEAR LOOSE CLOTHING, JEWELRY, OR LONG HAIR WHEN OPERATING.</p>
	<p>DO NOT LEAVE CHUCK KEY IN THE CHUCK LEAVING THE KEY WILL CAUSE IT TO COLLIDE DURING ROTATION.</p>		<p>CRUSH HAZARD STAY CLEAR OF MOVING OR FALLING MATERIAL.</p>

Control Box

WARNING

<p>ELECTRIC SHOCK WARNING.</p> <p>DO NOT UNPLUG BOX BEFORE POWERING OFF FIRST.</p>

Material Control Lifter

WARNING	
	<p>PINCH POINT MOVING PARTS. KEEP CLEAR DURING OPERATION.</p>
	<p>MOVING PARTS KEEP CLEAR KEEP CLEAR OF DEBRIS AND WIRES.</p>

1.3 Recommended PPE for Operating the Dragon A400

1.3.1 Eye Protection

Shaded safety glasses are required during cutting operations of the machine. Ensure the shade is based on the amperage of the plasma torch being used. It is important the operator and anyone observing the machine wear welder's glasses or a welder's mask. Placing a welding curtain between the machine and other areas of the workspace is also recommended. Refer to the Occupational Safety and Health Administration (OSHA) standards to determine proper safety glass shading and/or welding curtain for the cutting torch amperage being used.

! Danger !



The cutting torch emits ultraviolet light. Looking directly at the plasma stream can damage human retinas.

The minimum ANSI eye protection recommendations:

- Less than 40 amps - shade 5
- 41 to 60 amps - shade 6
- 61 to 300 amps - shade 8

For non-cutting operations, clear safety glasses are recommended.

1.3.2 Footwear

The Dragon A400 is a metal working machine and metal materials can be extremely heavy. A piece of dropped material could cause injury to the operator or observers. Also, the Torch emits sparks and possibly hot torch slag. It is highly recommended that the operator wear safety shoes or boots while operating the Dragon A400.

1.3.3 Heat-Resistant Gloves

The plasma torch will introduce extreme heat into the material during the cutting process. The operator should take caution handling newly-cut parts. Always wear heat resistant gloves when handling parts produced by the Dragon A400.

! Warning !



Due to the extreme temperatures that result from the plasma cutting process, parts cooled in water in the parts catcher can still be extremely hot. Always use caution when handling newly-cut parts.

! Danger !



The plasma arc of the Torch can cause severe injury or even death. Never approach the Torch while it is activated and operating.

1.3.4 Hearing Protection

While the Dragon A400 is relatively quiet, it is recommended that the operator wear hearing protection as specified per the facility safety requirements.

1.3.5 Breather Mask or Ventilation System

Plasma dust and debris is toxic, and inhalation can cause respiratory difficulties or other complications. It is recommended that the operator and any observers wear a breathing mask, or that the shop be equipped with an effective ventilation system for safe operation of the Dragon A400.

Important

The Dragon A400 Material Coolant System greatly reduces smoke and vapor emitted by the machine. Bend-Tech recommends use of the Material Coolant System whenever possible. The Coolant System is especially effective when working with aluminum or stainless steel.

! Danger !



Servicing the plasma unit with power connected can result in electric shock which can lead to severe injury or death. Disconnect power before servicing the torch or plasma unit.

! Danger !



Do not use combustible fuel gases or oxidizing gases in the plasma cutting process. Use of these types of gases can result in explosive conditions during cutting operations.

1.4 Operational Safety

1.4.1 Guards

Do not operate the machine without safety guards in place.

1.4.2 Machine Inspection

Perform an inspection of the machine before each startup, making sure all electrical cords and cables that function as part of moving assemblies are secure and fastened. Ensure all tools are fastened securely. Ensure all E-stop switches are disengaged.

1.4.3 Machine Operational Movement

While a program is running, the Trolley and Toolhead can move rapidly at any time through its short/long travel feed rate procedures. The operator and bystanders should stay clear of the Trolley and Toolhead during machine operation.

! Warning !



The Trolley, Toolhead, and Gate are pinch points. Stay clear during machine operation.

1.4.4 Material Securing

Ensure that any material loaded into the machine is securely fastened in the Chuck and is snug in the Gate.

! Warning !



Improperly secured material may cause injury.

1.5 Pinch Points

Use caution in the area of pinch points. There are many pinch point locations identified on the Dragon A400 including the Gate assembly, Toolhead, Trolley and Material Support Lift. It is advised to use caution in these areas and stay clear of them during machine operation.

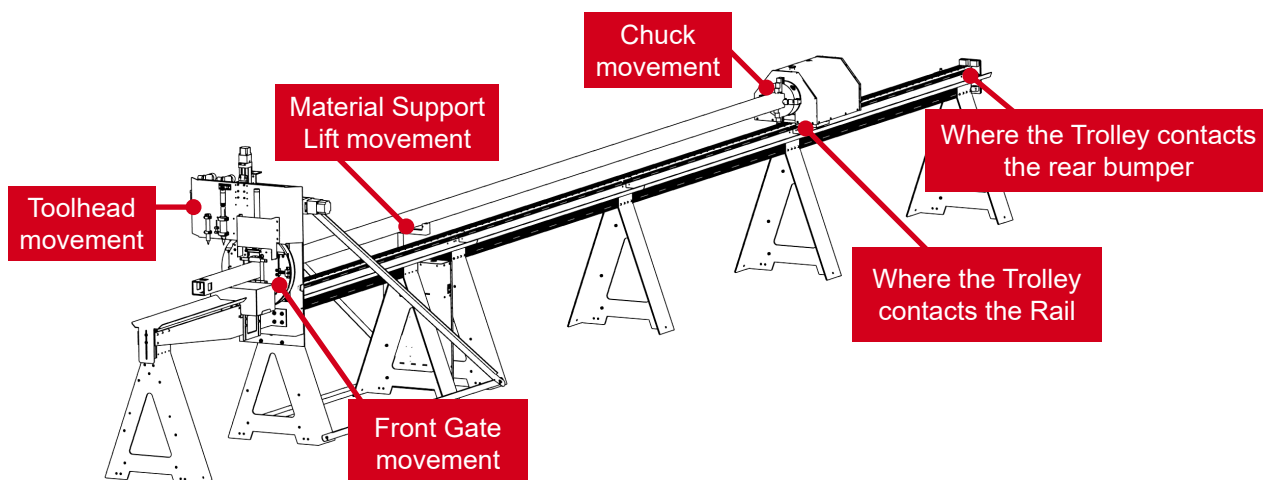

1.6 Emergency Stops (E-Stops)

1.6.1 E-Stop Overview

There are four external emergency stop (E-Stop) buttons located on the Dragon A400 machine. There is one E-Stop on the Tail of the machine, one on the Trolley cover, and one on each side of the Gate. These four emergency stops completely shut power off to all motors and outputs. To re-enable the machine after pressing an E-Stop, the E-Stop must be disengaged and power to the motors must be initialized by pressing the green light on the Control Box. If the green light doesn't initialize, this is an indicator that an E-Stop is still engaged. The green light indicates the motors have power.

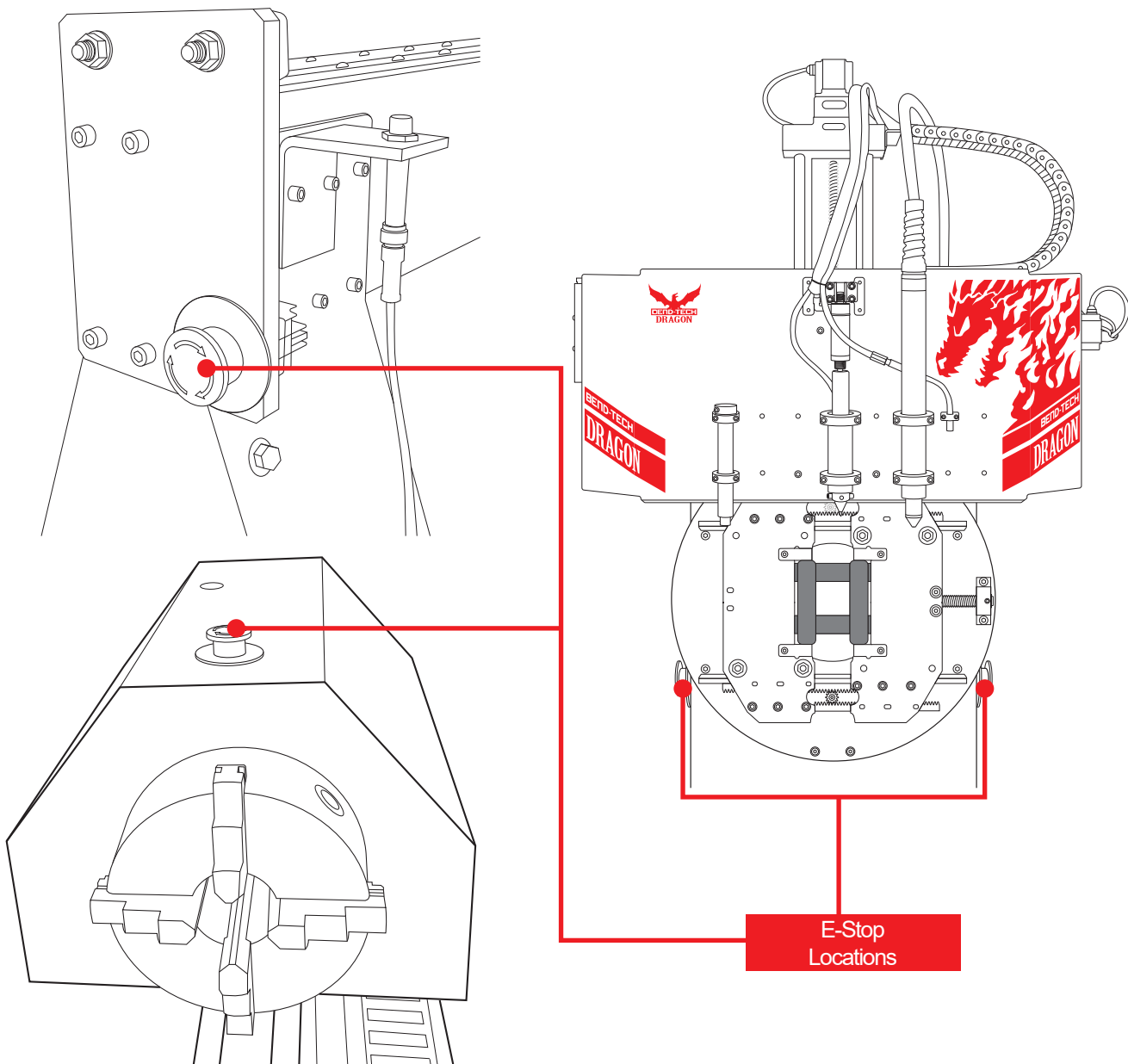

1.6.2 Control Screen E-Stop

There is an additional emergency stop located on the machine control screen. This E-Stop does not cut power to any motors or outputs, but will temporarily disable any software that is being used. This will stop any project that is being run, without disconnecting power to the motors.

1.6.3 Re-Home after an Emergency Stop

When an E-Stop is engaged, the machine will need to be re-homed after the E-Stop is cleared and disengaged.

1.7 Electrical Servicing

1.7.1 Power Down Before Servicing

Completely power off the Control Box before handling any electrical components. Electrical components include all motor connections, motor cables, sensors, sensor cables, emergency stops, laser cable, and Torch cable.

! Danger !



Do not touch 120VAC components inside the Control Box without first disconnecting the machine from its power source.

! Warning !



Never disconnect a Motor Cable with power applied.

1.8 Material Weight

1.8.1 Weight Limit

Material weight limit for the Dragon A400 should not exceed 400 lbs. This is the maximum weight of material the Trolley can support while still operating safely.

! Danger !



Exceeding the material weight limit of the Dragon A400 can result in serious injury to the Operator and/or bystanders.

! Caution !



Exceeding the material weight limit can affect performance and possibly damage the Dragon A400.

1.9 Material Length

1.9.1 Material Support Lift

Some non-rigid materials, or excessively long materials, can sag and cause material to raise at the Toolhead. This introduces the danger of material contacting the Torch or damaging the Engraver. Material longer than 10 ft. or thinner material may need to be supported by the Material Support Lift in order to avoid contacting the Torch or damaging the Engraver.

1.10 Modifications To The Machine

1.10.1 Unauthorized Modifications

Performing unauthorized modifications to the Dragon A400 is not recommended. Bend-Tech, LLC is not responsible for damage resulting from modifications to the Dragon A400.

! Caution !



Bend-Tech does not recommend unauthorized modifications to the Dragon A400. Contact Bend-Tech service representatives with any questions regarding operation or capabilities of the machine.

Unauthorized modifications include modifications to the machine's G-code that alter the factory settings and adversely affect the operation of the machine.

1.10.2 Factory Parts Kits and Updates

Parts kits and update packages are manufactured and sold by Bend-Tech, LLC. Customers may choose to install these kits and updates themselves. However, the Customer should have a thorough understanding of the machine and the service actions being performed. If a Customer has any doubts regarding their ability to install parts kits or update packages contact Bend-Tech for assistance.

1.11 Other Safety Information

The Dragon A400 may have subassemblies supplied with independent warnings. It is the Operator's responsibility to familiarize themselves with all possible hazards of the machine.

1.12 More Information

Bend-Tech is continuously updating information regarding the Dragon A400. Users can access updated and supplemental information online at www.bend-tech.com or speak with a technical representative directly by calling 651-257-8715.

1.13 Recommended Safety Guidelines

- Keep unauthorized personnel away from the Dragon A400 work area.
- Keep the work area clean and free of debris.
- Stay clear of the machine and any moving parts during machine operation.
- Stay clear of the Toolhead during operation.
- Never operate the machine while under the influence of alcohol or drugs.
- Wear appropriate PPE at all times while operating the machine.
- Keep flammables away from the machine during operation.
- Risk of electric shock - avoid touching exposed wires while the machine is powered.
- Always power off the machine and disconnect from main power source before servicing electrical components.
- Do not exceed the machine's capacities.
- Do not wear loose-fitting clothing or jewelry while operating the machine.
- Be aware of sharp edges on cut material.
- Avoid handling hot parts.

02

Maintenance

2.1 Dragon A400 Maintenance Overview

In order to keep the Dragon A400 running at peak performance, it is important to follow the maintenance schedule. Following this maintenance schedule will help maximize the machine's long-term performance and avoid down time. The plasma cutting process produces dust, slag, smoke and other contaminants that can build up on Dragon A400 components. If not maintained, these contaminants can affect the performance of the machine.

The Dragon A400 is a machine which relies on mechanical components to perform its operations. As with any machine, these components can wear out over time. Maintaining them is key to maximizing the service life of the machine.

2.2 Daily Maintenance

The Dragon A400 requires specific daily maintenance in order to continue to function like new. The Operator should set up a Daily Maintenance checklist that includes all of the points outlined in this section.

2.2.1 Clean the Gate

Use compressed air to blow dust and debris from the rollers, bearings, racks, and other components of the Gate. Then use brake cleaner to clean the Gate.

2.2.2 Clean the Support Beam

Clean the support beam using compressed air to blow any dirt or debris that may have accumulated. After blowing off the support beam, clean the rails by wiping them down with a clean rag.

2.2.3 Clean the Rack

Check the Rack for debris buildup and clean with compressed air. If the compressed air strips the lubricant from the Racks, re-lubricate them with WD40 Specialist Spray & Stay Gel Lubricant.

2.2.4 Check the Coolant Level

For Dragon machines equipped with a Material Cooling System, verify that the level of coolant is adequate. Coolant can be clean water or other coolants, such as anti-rust solutions.

2.2.5 Clear the Part Catcher

Remove any loose parts from the Parts Catcher. Clean the Parts Catcher of slag and debris. If necessary, add water to the Parts Catcher.

2.2.6 Check the Air Pressure

Check the air pressure at the air inlet on the Control Box. Pressure should be within the recommended 100-130 psi range.

2.2.7 Clean the Work Area

It is important to keep the work area surrounding the Dragon A400 clean and free from dust and safety hazards. Sweep the work area regularly and remove any debris that may be around the machine.

2.2.8 Check the Plasma System

Refer to your plasma system maintenance guide regarding scheduled maintenance and procedures.

2.3 Weekly or Every 40 Hours

Each week or 40-hours of runtime, the Dragon will require additional maintenance from the Operator. Maintenance in this section should be combined with maintenance outlined in section 2.2: Daily Maintenance.

2.3.1 Clean Grease and Oil Buildup

Wipe off any excess grease, oil or grime that may have accumulated on the machine.

2.3.2 Check Electronic Connections

Inspect all electrical connections. Perform this inspection with the machine powered off, and disconnected from power sources. Ensure all electrical connections are hand tight and in good working order.

2.3.3 Clean Chuck and Trolley

With a clean rag, clean the Chuck and Trolley of the machine.

2.3.4 Lubricate the Gear Rack

Clean and lubricate the Gear Rack with WD40 Specialist Spray & Stay Gel Lubricant.

2.3.5 Actuators and Lead Screws

Grease the actuators on the Toolhead, Gate Lead Screws, and Material Support Lifter lead screw. Apply light coating of NLGI2 grease. Ensure Actuators and Lead Screws are clean before applying grease.

2.3.6 Clean and Re-lubricate the Roller Bearings

Clean and re-lubricate the roller bearings that the rollers are housed in. Do not lubricate the rollers themselves. Grease is recommended if the bearings are removed for cleaning, otherwise use spray gel lubricant.

2.4 Monthly or 150 Hours

Monthly maintenance should be performed each month or after 150-hours of service time. Scheduled monthly maintenance should include all previous maintenance procedures outlined.

2.4.1 Check the Fasteners

Perform a comprehensive check of the machine verifying that all fasteners are present and secure. Ensure all fasteners are appropriately tightened. Replace missing or damaged fasteners.

2.4.2 Clean and Fill the Material Cooling System Reservoir

For machines equipped with a Material Cooling System, drain and refill the system to the proper level. Fill the reservoir with clean coolants.

2.4.3 Check the Eccentric Bearings

Verify the eccentric bearings on the Trolley and the Gate are adjusted properly. Ensure that the eccentric bearings roll smoothly and there is no play.

2.4.4 Check the Emergency Stops

Inspect the E-Stop buttons for loose wire connections and proper operation. Check that each E-Stop is functioning correctly. When an E-Stop is triggered the green power light will turn off.

2.4.5 Clean and Lubricate the Racks

Clean the Gear Racks and re-lubricate with WD40 Specialist Spray & Stay Gel Lubricant.

2.4.6 Check Backlash

Check backlash in X-Axis. Adjust if necessary.

2.5 Quarterly or 500 Hours

Quarterly maintenance should take place every three months or after 500-hours of operation. Quarterly maintenance should include all previous maintenance procedures outlined.

2.5.1 Clean Coolant Screens

For machines equipped with a Material Cooling System, inspect and clean the system screens.

2.5.2 Grease Pillow Block Bearings

Reapply grease to the pillow block bearings on the Trolley. Bend-Tech recommends hi-temp red lithium grease, NLGI2.

2.5.3 Comprehensive Cleaning

Clean entire machine.

2.6 Bi-Annually or 1000 Hours

Bi-annual maintenance should take place every six months or after 1000 hours of operation. Bi-annual maintenance should include all previous maintenance procedures outlined.

2.6.1 Clean the Chuck

Remove the Chuck, disassemble jaws and clean. Ensure the teeth are reinstalled in the proper location and in the proper order.

2.6.2 Check Level and Straightness

Check to ensure the Rail is level and adjust as necessary. Check the Rail for straightness using the string provided with the machine. See Startup and Training Manual Part 2 section 1.2.3.

2.7 Annually or 2000 Hours

Annual maintenance should take place each year or after 2000 hours of operation. An annual or 2000 hour maintenance procedure centers around checking the backlash in the drive motors and gears. It should also include all previous maintenance procedures outlined.

2.7.1 Check Rack Spacing

Check the Rack spacing. Adjust if necessary.

Attention

After reviewing the Startup Manual Part 1,
please proceed to Startup Manual Part 2.

Bend-Tech, LLC

729 Prospect Ave. Osceola, WI 54020
1-651-257-8715

sales@bend-tech.com
www.bend-tech.com