

# BEND-TECH DRAGON A400

## Startup Manual

### Part 2: Machine Overview, Inspection, and Startup

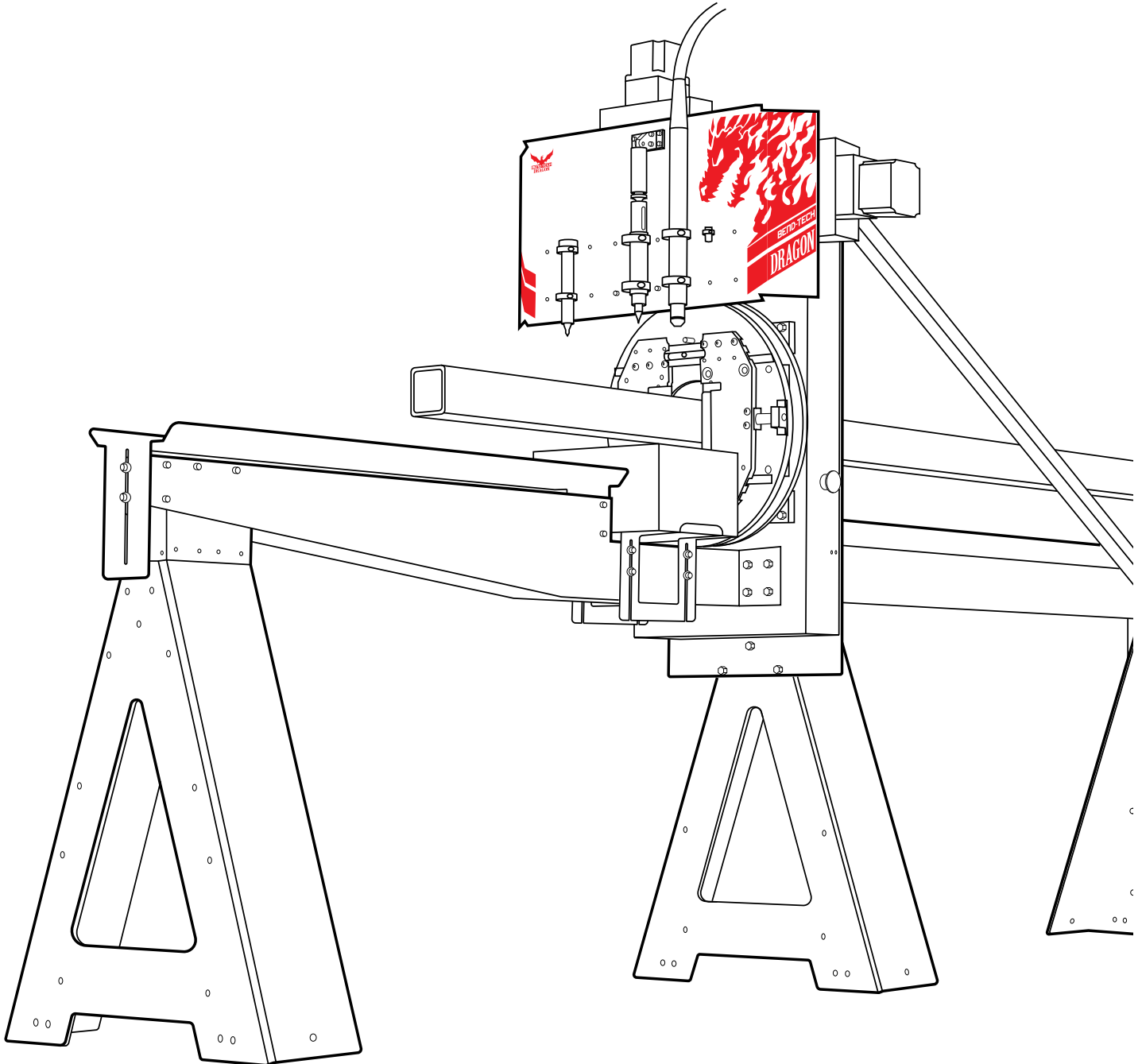

©2022 Bend-Tech LLC

All rights reserved. The information in this manual is subject to change without notice. Bend-Tech LLC strives to produce the most complete and accurate information regarding its products. We are constantly working to improve and advance our products to increase performance, user satisfaction and experience. Bend-Tech LLC assumes no responsibility for errors or omissions regarding this manual. Bend-Tech LLC assumes no liability for damages resulting from the use of the information contained in this publication.

# **Dragon A400**

**Startup Manual**  
Revision 7.1

English  
Original Instructions

October 2022

Bend-Tech LLC  
729 Prospect Ave.  
Osceola, WI 54020 USA

(651) 257-8715  
[www.bend-tech.com](http://www.bend-tech.com)  
[support@bend-tech.com](mailto:support@bend-tech.com)

# Contents

---

**Contents .....iv**

**01**

**Machine Overview ..... 7**

- 1.1 Introduction ..... 7
- 1.2 Gate Overview ..... 7
  - 1.2.1 Gate Eccentric Bearing ..... 8
  - 1.2.2 Gate Lead Screws ..... 9
  - 1.2.3 Gate Adjustment ..... 9
  - 1.2.4 Gate Clamp ..... 9
- 1.3 Material Support Lift Overview. .... 10
  - 1.3.1 Material Support Lift Operation ..... 10
  - 1.3.2 Air Cylinder Adjustment ..... 11
- 1.4 Toolhead. .... 11
  - 1.4.1 Toolhead Actuators ..... 11
  - 1.4.2 Marker Holder ..... 12
  - 1.4.3 Engraver ..... 12
  - 1.4.4 Engraver Air Regulators. .... 12
  - 1.4.5 Torch ..... 12
  - 1.4.6 Laser Light. .... 13
- 1.5 Electrical Components Overview ... 13
  - 1.5.1 Emergency Stops (E-Stops) .. 13
  - 1.5.2 E-Stop Wiring. .... 13
  - 1.5.3 Homing Sensors ..... 14
  - 1.5.4 Homing Sensor Designations and Locations ..... 14
- 1.6 Motor Cable Connections Overview 15

- 1.7 Hypertherm Unit. .... 15
  - 1.7.1 Hypertherm Overview ..... 15
  - 1.7.2 Hypertherm Cable ..... 15
  - 1.7.3 Ground Connection ..... 15
  - 1.7.4 Amperage ..... 16
  - 1.7.5 Air Supply. .... 16
  - 1.7.6 Gas ..... 17
  - 1.7.7 Consumables. .... 17
  - 1.7.8 Consumables Part List. .... 17

**02**

**Machine Inspection ..... 18**

- 2.1 Machine Inspection ..... 18
- 2.2 Rail Inspection ..... 19
  - 2.2.1 Check Rail Assembly. .... 19
  - 2.2.2 Check Rail Level ..... 20
  - 2.2.3 Check Rail Straightness ..... 21
- 2.3 Electrical Inspection ..... 22
  - 2.3.1 Motor Cables ..... 23
  - 2.3.2 Motor Cable Locations. .... 24
  - 2.3.3 Axis Sensor Cables ..... 24
  - 2.3.4 Emergency Stop Cables ..... 25
  - 2.3.5 Ethernet Port ..... 25
  - 2.3.6 Laser Light Connection ..... 26
  - 2.3.7 Torch Connection. .... 26
  - 2.3.8 Connect the Ground Cable ... 26
  - 2.3.9 Check the Breakout Board. ... 27

2.3.10 Connect Power and Check for 5 Volts . . . . . 27

2.3.12 Check E-Stops. . . . . 28

2.4 Air Line Connection . . . . . 28

3.6.1 Hypertherm Power Switch . . . . 36

3.6.2 Hypertherm Cut Type. . . . . 37

3.6.3 Hypertherm Air Supply. . . . . 37

3.6.4 Hypertherm PSI Settings. . . . . 37

3.6.5 Hypertherm Cut Settings . . . . 37

## 03

### Machine Control Startup..... 29

3.1 Machine Control Startup . . . . . 29

3.2 Booting Up The Dragon A400 . . . . 29

    3.2.1 Power On Computer . . . . . 29

3.3 Power On Control Box . . . . . 30

    3.3.1 Main Power Switch . . . . . 30

    3.3.2 Green Power Button . . . . . 30

    3.3.3 Launch Bend-Tech 7x . . . . . 30

    3.3.4 Dragon A400 Software Color Designations. . . . . 30

    3.3.5 Bend-Tech Launcher . . . . . 31

    3.3.6 Machine Control. . . . . 31

    3.3.7 Mach3 Machine Control . . . . 32

    3.3.8 Enable Machine. . . . . 32

3.4 Jog Controls System Check. . . . . 32

    3.4.1 Open Jog Controls. . . . . 32

    3.4.2 Motor Location and Operation Index. . . . . 33

    3.4.3 Jogging the Machine . . . . . 33

3.5 Homing The Machine. . . . . 33

    3.5.1 Homing an AXIS . . . . . 34

    3.5.2 Axis Definition Table. . . . . 34

    3.5.3 Jog the Trolley . . . . . 34

    3.5.4 Home All Axis. . . . . 35

3.6 Hypertherm . . . . . 36

# Contents

# Machine Overview

## 1.1 Introduction

---

This chapter overviews general information on the Bend-Tech Dragon A400. This general information is a starting point to learn about the Dragon A400. For detailed information on operation and troubleshooting, please refer to your Bend-Tech Dragon A400 Operator's Manual.

## 1.2 Gate Overview

---

The gate is located at the front of the Dragon A400. The gate works in conjunction with the chuck to support and move the material through the cutting process. There are two styles of gate that the Dragon A400 can come equipped with: a non-powered gate and a powered gate.

Gate Type	Function
Non-Powered Gate	Round, square or rectangle material. Does not support angle or channel
Powered Gate	Round, square, rectangle, angle or channel material. Essential when processing angle or channel.

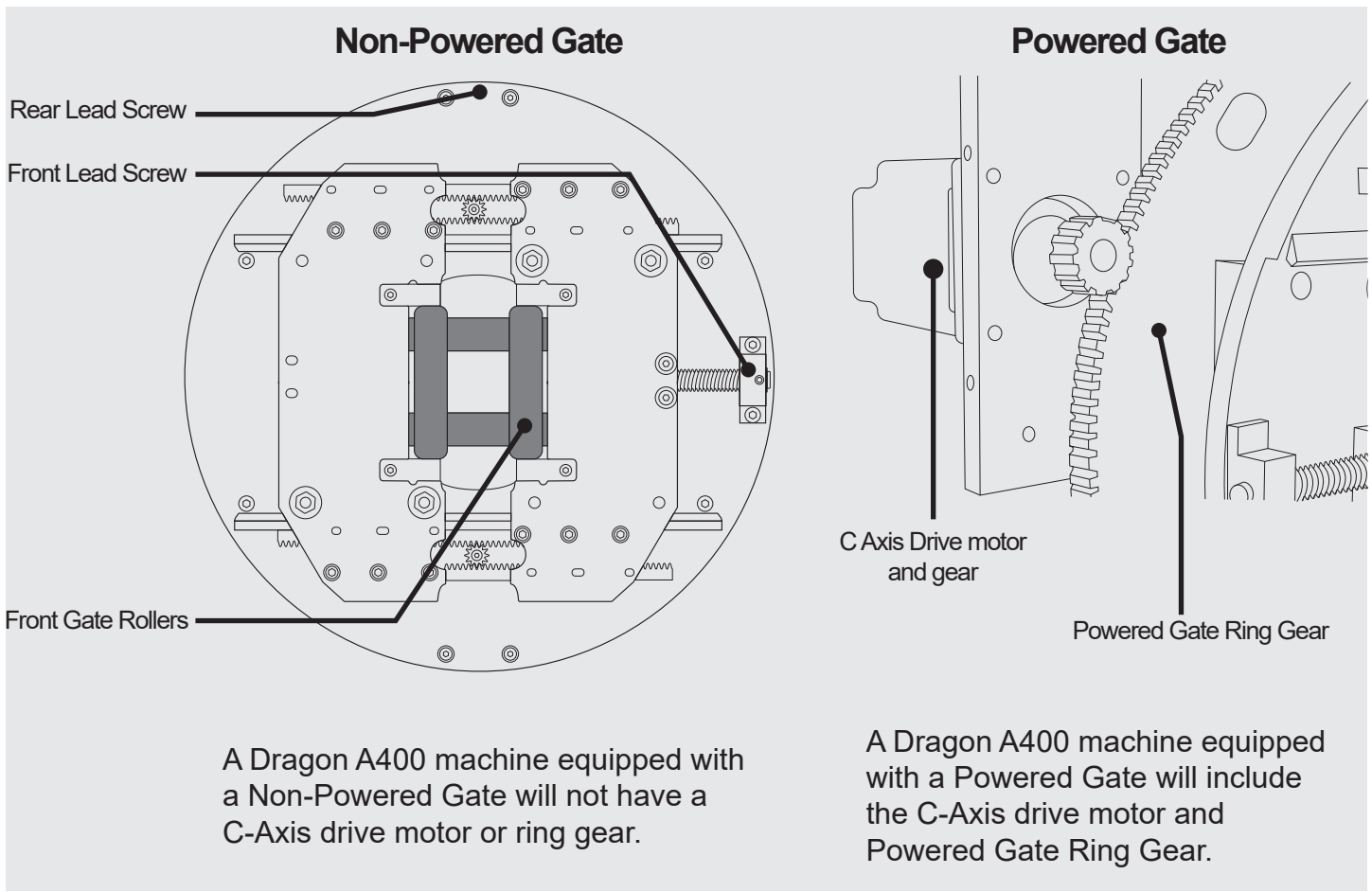

## Important

Keeping the gate clean is key to maintaining optimum performance of the Dragon. Refer to maintenance guidelines for the gate for cleaning procedures and intervals.

### 1.2.1 Gate Eccentric Bearing

The gate rides upon three bearings located on the back face of the gate assembly. The gate should ride smoothly on its bearings with no binding. If there is play in the gate or if the gate binds while moving, the gate eccentric bearing may need adjustment. Please, contact customer support before adjusting the eccentric bearing.

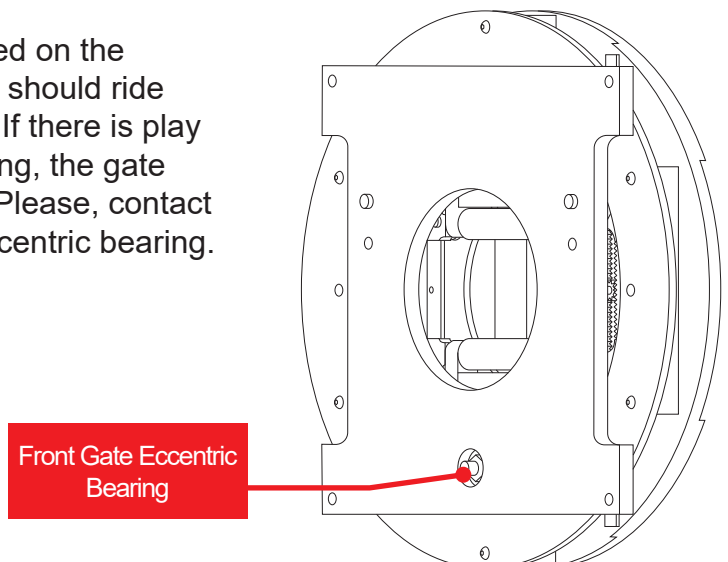



## 1.2.2 Gate Lead Screws

The lead screws are used to adjust the opening of the gate. The gate uses two lead screws, positioned 90 degrees from each other. Adjust the lead screws using a ¼" allen wrench, which is provided with the machine. Turning the lead screws clockwise closes the gate, and turning them counterclockwise opens the gate. The gate lead screws should operate smoothly with minimal force and no binding throughout the travel.

## 1.2.3 Gate Adjustment

When loading material, the gate should be adjusted so that the rollers are snug against the material. The rollers should not be overtightened, and should spin by hand, but not spin freely. The material needs to move freely within the gate rollers with no play and minimal effort.

Without material loaded into the gate, the gate rollers should spin freely without binding or sticking.

### Note

*The gate will only need to be adjusted when changing material types or sizes, or for removing remnant material.*

## 1.2.4 Gate Clamp

The gate clamp is used on non-powered gates to lock the gate into one position. It is used only for round stock. The gate clamp is critical to keeping round stock in position during cutting. Always lock the gate with the lead screws in the 12 o'clock and 3 o'clock positions.

### Important

Machines equipped with the powered gate do not come equipped with a gate clamp.

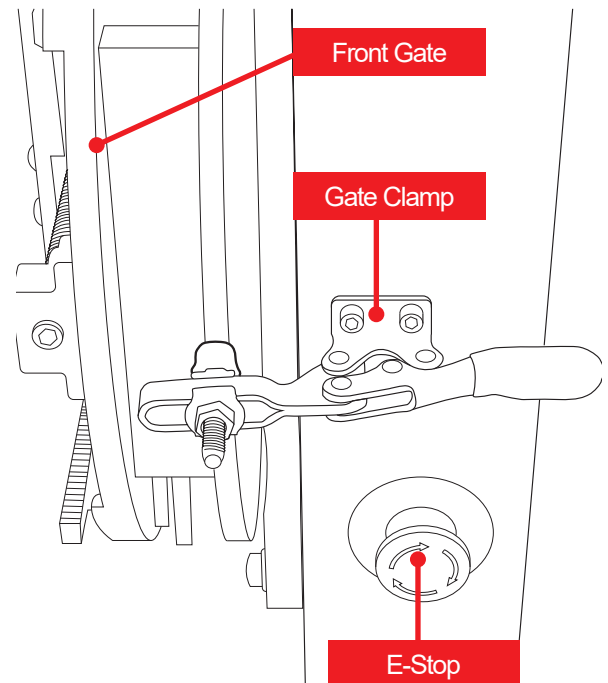

## 1.3 Material Support Lift Overview

The material support lift is used to support extremely long or thin material. Long material may sag under its own weight which can affect machine operation and accuracy. The material support lift will accommodate up to 6-inch OD round stock or 4-inch square stock. By default the material support lift will activate for material stock over 10 feet in length (3 meters).

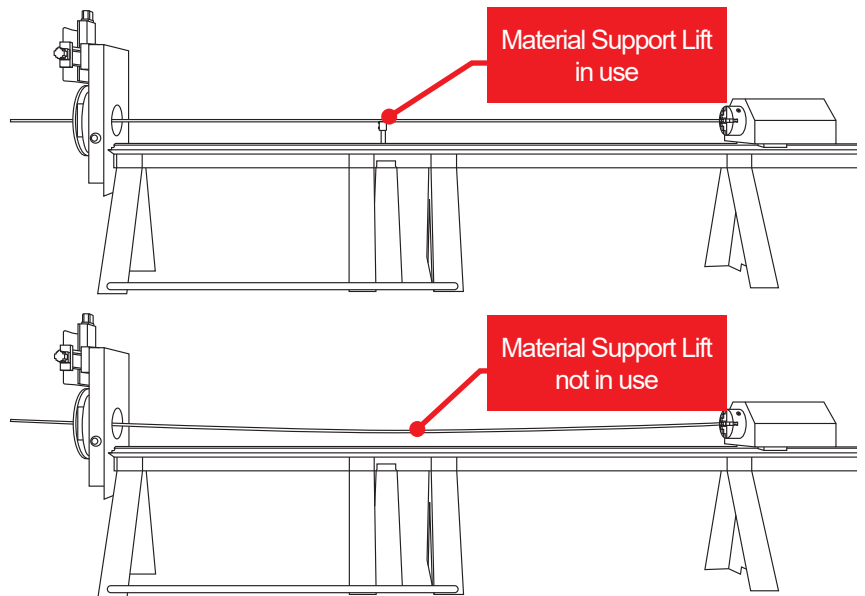

### 1.3.1 Material Support Lift Operation

The material support lift is powered by the B-Axis motor which moves the lift up and down. The rotation of the material support lift is achieved via a pneumatic cylinder. The pneumatic controls for the material support lift are pre-set to 60 psi. However, line pressure going into the machine can affect the speed of operation of the material support lift so some adjustment may be necessary.

## Important

When adjusting the needle valves on the Material Support Lift air cylinder it is best to turn them  $\frac{1}{4}$  turn at a time to avoid over adjustment and possible damage to the assembly.

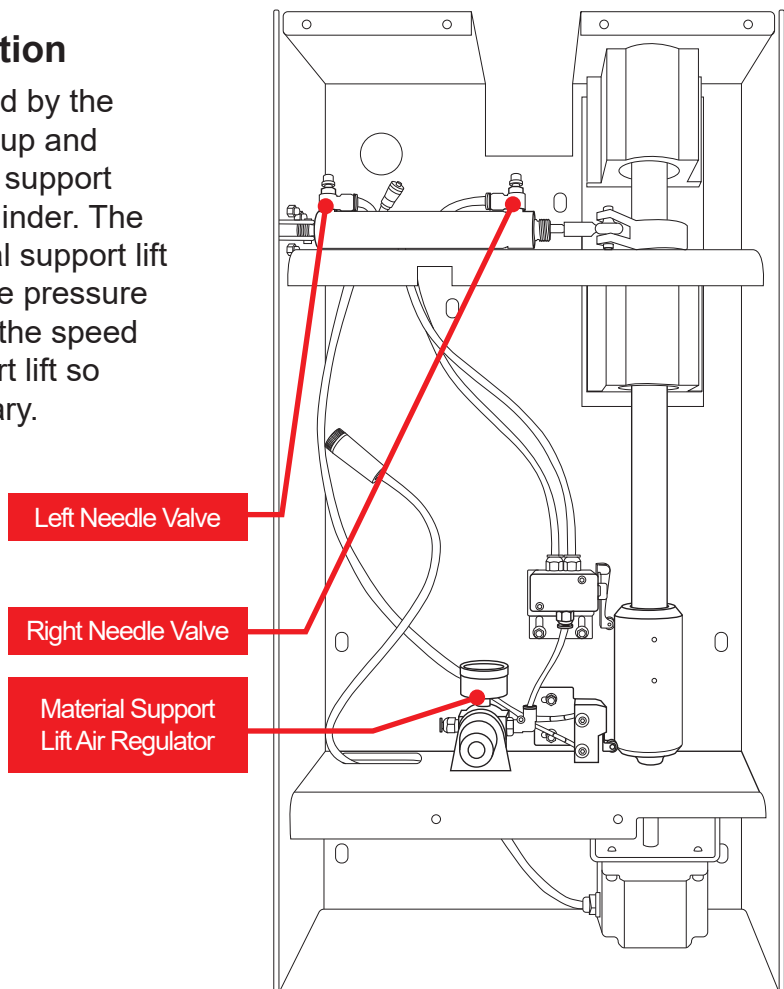

### 1.3.2 Air Cylinder Adjustment

The speed of the material support lift rotation is controlled by a needle valve adjustment screw on either end of the air cylinder. The right side needle valve adjustment controls the inward rotation of the material support lift (toward the Rail). The left side needle valve adjustment controls the outward rotation of the material support lift (away from the Rail).

## 1.4 Toolhead

The toolhead on the Dragon A400 serves as the tool mount, and the vehicle for engaging the tools vertically and horizontally during the machine's operation. It is located at the front of the Dragon A400. The marker holder, engraver, torch, and laser light are mounted to the toolhead.

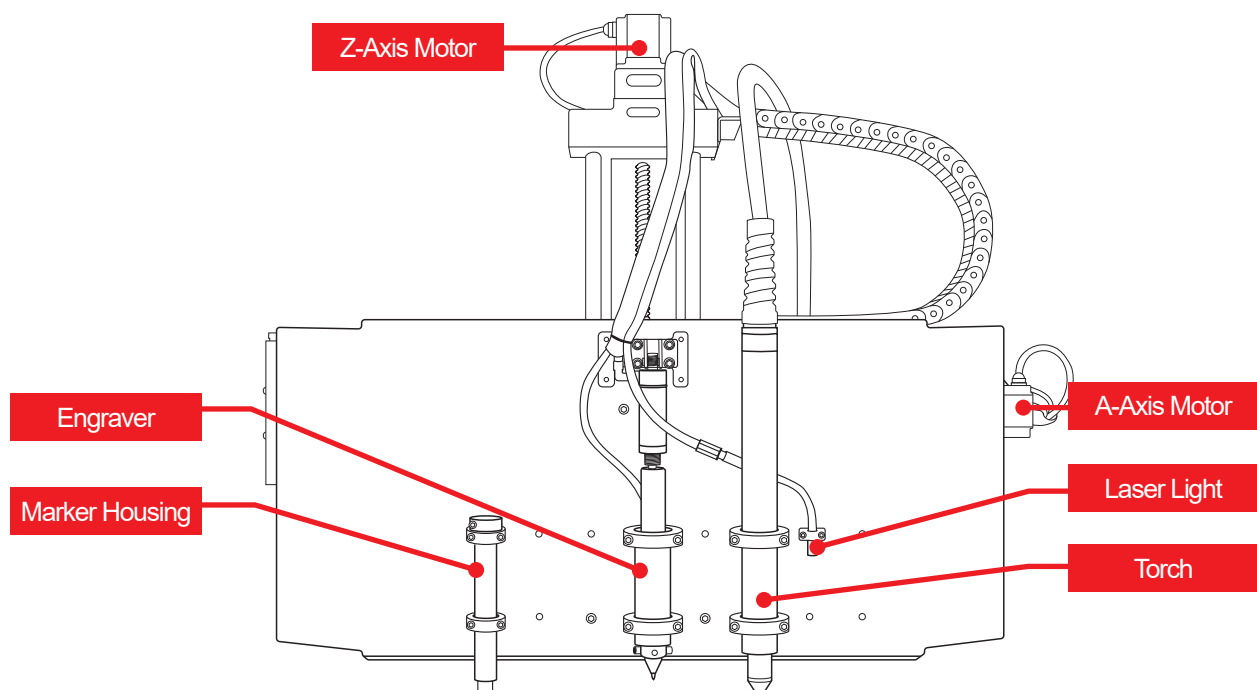

### 1.4.1 Toolhead Actuators

The toolhead is controlled by the Z-Axis and A-Axis motors. The motors use actuators to perform vertical and horizontal movement of the toolhead. The actuators should be kept clean and free of dust and debris. The actuators are key to smooth, accurate, and consistent operation of the toolhead.

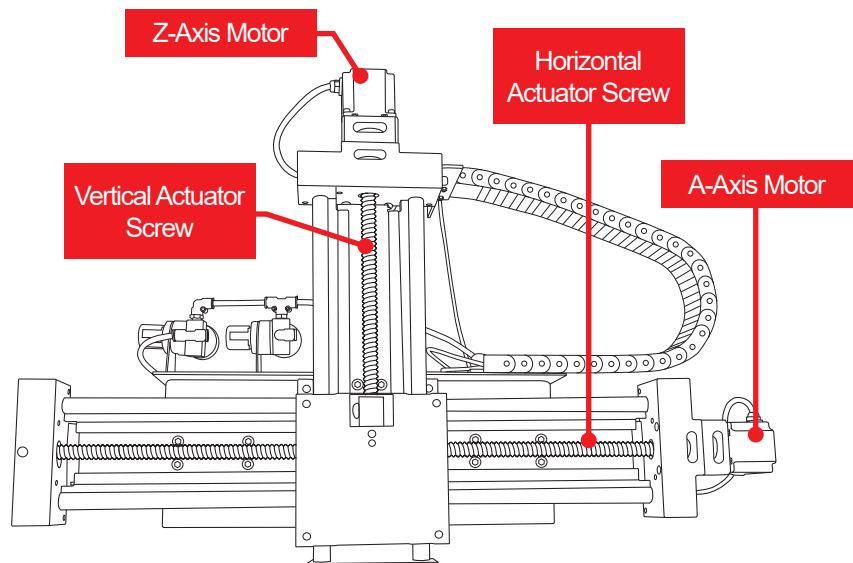

### 1.4.2 Marker Holder

The marker holder is mounted on the left side of the toolhead. The marker holder sits loose in its mount on the toolhead so it is able to ride over material easily and without damaging the marker. Depending on the type of marker being used it may be necessary to modify the marker body or use a piece of tape to keep the marker secure in the holder.

#### Note

*Material cleanliness will affect marker life. When a project requires heavy use of the marker, clean the material before loading it into the machine. Always keep the marker capped when not in use.*

### 1.4.3 Engraver

The engraver is mounted in the center of the toolhead. When the engraver is engaged, an air cylinder is pressurized and the tool is pushed down to meet the material. The pressurized cylinder, along with the bleeder valve, allows the engraver to ride over contours in the material without damaging the tool.

### 1.4.4 Engraver Air Regulators

The engraver is driven by pressurized air. It uses two separate regulators located just behind the toolhead. The left regulator controls the engraver and is pre-set at the Bend-Tech manufacturing facility to 70 PSI. The right regulator controls the engraver air cylinder and is pre-set at the Bend-Tech manufacturing facility to 5-10 PSI.

The engraver cylinder and air regulator also use an air bleeder screw. The bleeder screw is located on an air line extension just off the engraver air regulator. When setting engraver air pressure, ensure the bleeder screw is open all the way.

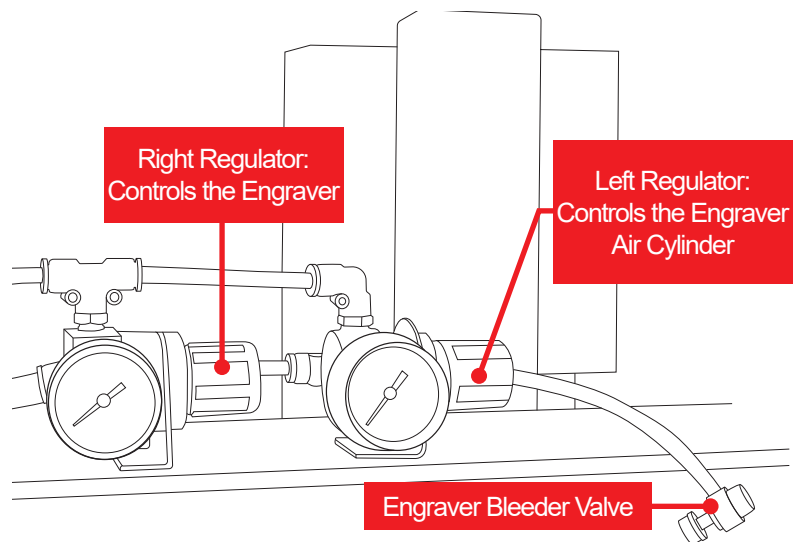

Engraver Air Pressure Settings	
Engraver	70 PSI
Engraver Actuator Cylinder	5-10 PSI

### 1.4.5 Torch

Inspection of the torch is covered in Chapter 2 of the Startup and Training Manual Part 3.

## 1.4.6 Laser Light

The laser light is used to calibrate the Dragon A400 tools in relation to the material. The laser light is mounted and calibrated at the Bend-Tech manufacturing facility. No adjustment of the laser light is necessary.

# ! Warning !



The laser light can damage human retinas. Never look directly into the laser light.

## 1.5 Electrical Components Overview

The Dragon A400 uses sensors, switches, and cables to connect each Axis of the machine to the computer, and to allow the machine to be shut down in case of an emergency. Inspecting these electrical components on initial startup as well as on a regular basis, will ensure the Dragon operates on a long-term basis.

### 1.5.1 Emergency Stops (E-Stops)

There are four Emergency Stop (E-Stop) buttons on the Dragon A400. There is one on either side of the toolhead, one on the trolley and one at the tail.

### 1.5.2 E-Stop Wiring

Check the wiring connections on the E-Stop switches to ensure secure connections. While these are secured at the Bend-Tech manufacturing facility, it is possible for these connections to become loose and result in a false E-Stop.

## Important

The E-Stop will have four wires. The Blue and Black wires are attached to terminals on the Orange Side. Brown and White wires are attached to terminals on the Green Side.

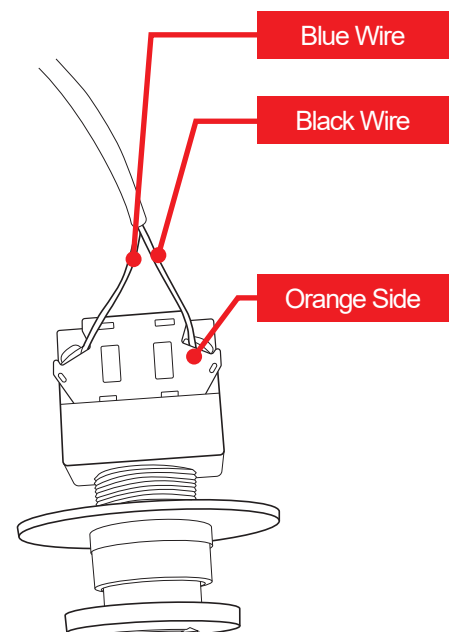

### 1.5.3 Homing Sensors

The Dragon A400 uses five homing sensors; six when the machine is equipped with the powered gate. Sensors should be checked for function on initial startup using a metal tool such as the blade of a screwdriver. When touched with a metal tool the sensor will either light up or the sensor light will go out, depending on the location and type of the sensor.

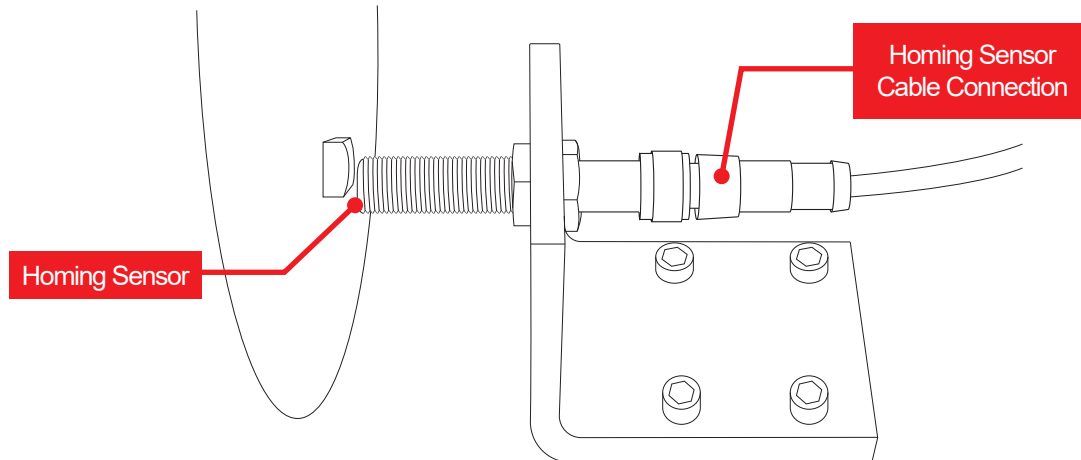

### 1.5.4 Homing Sensor Designations and Locations

Homing Sensor	Location
X Axis	The X-Axis Homing Sensor is located at the end of the beam of the machine. This sensor homes the Trolley on the beam.
Y Axis	The Y-Axis Homing Sensor is located at the Left rear of the Trolley, just in front of the Chuck Drive Gear. This sensor homes the Chuck.
Z Axis	The Z-Axis Homing Sensor is located at the top of the Toolhead mount on the front of the machine. The machine uses the Z-Axis homing sensor to home the Toolhead on its vertical axis.
A Axis	The A-Axis Homing Sensor is located on the right-hand side of the Toolhead mount. This sensor homes the Toolhead on its horizontal axis.
B Axis	The B-Axis Homing Sensor is located inside the Material Support Lift housing under the Material Support Lift collar sleeve. This sensor homes the Material Support Lift.
C Axis	The Homing Sensor for the C-Axis is located on the C-Axis Motor mounting bracket on the left side of the front of the machine. This sensor homes the Gate.

## 1.6 Motor Cable Connections Overview

---

The majority of motor cable connections and axis sensor cable connections are performed at the Bend-Tech manufacturing facility. The motor cables, axis sensor cables, and E-Stop cables will need to be connected to the control box.

## 1.7 Hypertherm Unit

---

The Dragon A400 uses a Hypertherm plasma unit to cut the material.

### Important

When a Customer purchases a Hypertherm unit as part of the Dragon A400 package, Bend-Tech will support the unit and contact Hypertherm regarding issues if necessary.

### Note

*Other plasma machines will work with the Dragon A400. Contact Bend-Tech Support for more information.*

### 1.7.1 Hypertherm Overview

Bend-Tech recommends the Hypertherm Powermax45 XP, Powermax65 or Powermax85 for use with the Dragon A400. The customer may purchase the Dragon A400 supplied with a Hypertherm unit or it can be purchased separately.

### 1.7.2 Hypertherm Cable

The Dragon A400 is supplied with a cable that connects the Hypertherm to the machine's control box. This allows the Hypertherm to connect directly to the machine without customization or modification.

### 1.7.3 Ground Connection

Bend-Tech recommends using a bolt to connect the ground cable on the Dragon A400 machine to the ground cable of the Hypertherm unit. This requires removing the cable from the alligator clamp on the Hypertherm cable and connecting it to the Dragon A400 cable.

### 1.7.4 Amperage

Hypertherm units are available for use with the Dragon A400 in 45, 65 and 85 amp versions. The amperage the customer chooses will depend on the thickness of material being cut as well as the amount the Dragon A400 will be utilized.

### 1.7.5 Air Supply

The Hypertherm Powermax 45 minimum air supply requirement is 6 cubic feet per minute (cfm) at 90 psi. When cutting thicker material it is possible that the Hypertherm unit will require higher air flow from the air supply. The customer should ensure the air supply for the Dragon A400 is appropriate to operate the Hypertherm as well as other working aspects of the machine. When connected to a separate air source the customer should ensure the air source is appropriate to supply the Hypertherm unit.

Air Line and Supply Requirements	
Pressure	90-135 psi
Air Line	3/8 in. minimum
Air Dryer	Yes
Air Filter	Yes
Oil/Oil Vapor Separator	Yes

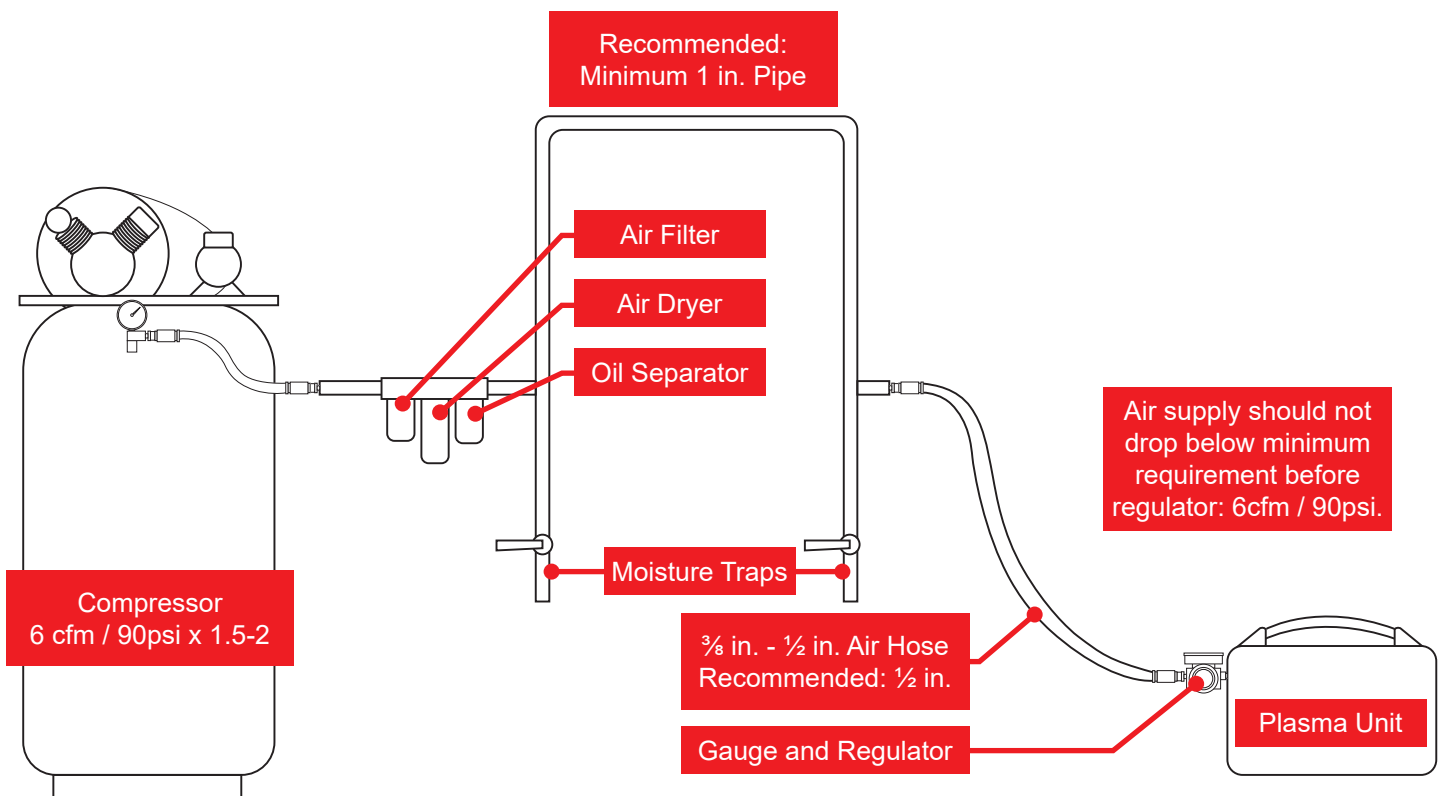



## 1.7.6 Gas

The customer may choose different types of gas for use with their particular Hypertherm unit. Bend-Tech recommends non-flammable gas or shielded gas.

# ! Danger !



When using the Dragon A400, do not use flammable gas in the plasma cutting process.

## 1.7.7 Consumables

It is recommended that the customer have additional consumables on hand when operating the Dragon A400. Worn consumables can result in wider and less accurate cuts. Consumables are available through Hypertherm website or via a Hypertherm distributor.

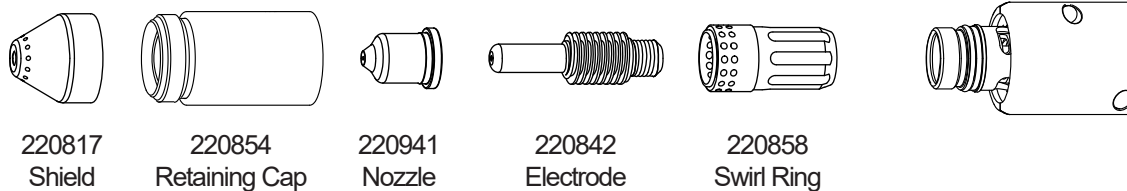

## 1.7.8 Consumables Part List

45 Amp Consumables			65 Amp Consumables			85 Amp Consumables		
Components	Standard	Fine Cut	Components	Standard	Fine Cut	Components	Standard	Fine Cut
Nozzle	220941	220930	Nozzle	220819	220930	Nozzle	220816	220930
Electrode	220842	220842	Electrode	220842	220842	Electrode	220842	220842
Shield	220817	220948	Shield	220817	220948	Shield	220817	220948
Swirl Ring	220857	220857	Swirl Ring	220857	220857	Swirl Ring	220857	220857
Retaining Cap	220854	220854	Retaining Cap	220854	220854	Retaining Cap	220854	220854

# Machine Inspection

## 2.1 Machine Inspection

---

After assembling the Dragon A400, it is important to conduct an initial inspection of components to ensure proper setup before powering on the machine for the first time. Please follow the procedures outlined in this chapter to ensure all components are inspected thoroughly.

### **! Caution !**



Electrical connections can cause injury to the operator. Always inspect electrical connections while the machine is powered down and disconnected from power sources.

### **Important**

Many times a flaw in the operation of the machine is the result of improper setup. Inspecting the machine is critical to eliminating variables in the troubleshooting process.

## 2.2 Rail Inspection

The rail forms the 'backbone' of the machine. It is assembled from rail guides that the trolley rides upon, and aluminum beams. Ensuring that the rail is assembled correctly and is straight and level is critical to the overall operation of the machine.

### 2.2.1 Check Rail Assembly

The rail is assembled in sections. The number of sections will depend on the length of the machine. There can be up to four rail sections on the Dragon A400.

1. Ensure that all the screws attaching the support legs to the beams are tight, and no screws are missing.



*There are two screws, one at the head and one at the tail of the machine, that are partially unscrewed on the side opposite of the cable track. These are used in checking the straightness of the machine and should not be adjusted.*

2. Ensure that each rail splice connects the rail sections as seamlessly as possible. Check that the four screws securing the rail splices to the beams at each joint are fastened properly.

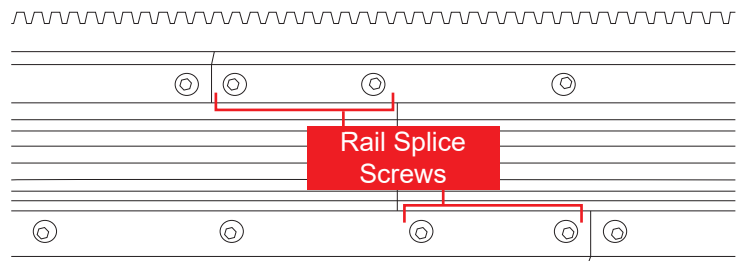

3. Ensure that the swivel levelers are installed. These will need to be adjusted if the machine is not level.
4. Bend-Tech recommends anchoring the machine to the floor. If completed, loosen the anchors and make adjustments if the machine is not level or straight.

### Rail Sections vs Rack Sections

There are three rail joints, labeled 3, 4, and 5. Ensure the numbers on the beams are aligned as shown in the diagram.

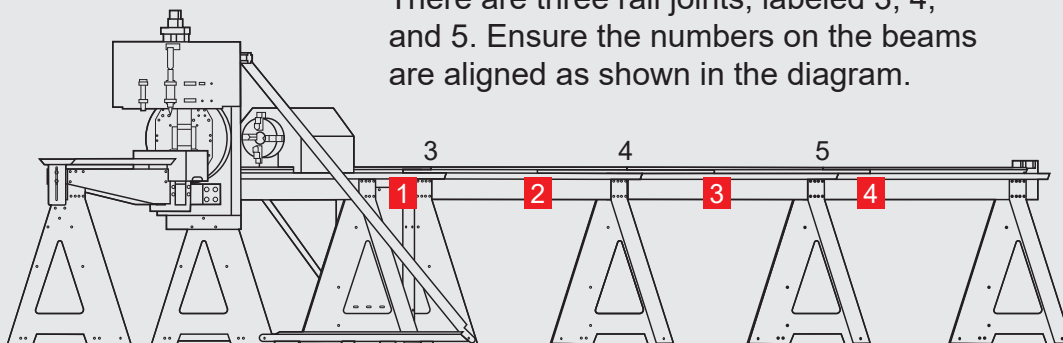

The four rack joints are labeled 1 - 4. Ensure the numbers on the racks are aligned as shown.

## 2.2.2 Check Rail Level

It is critical that the rail is level to ensure proper operation of the trolley, and proper feed of the material to the toolhead. If the rail is not level it can affect the operation of the machine and damage machine components.

1. Check each rail section for side-to-side level using a bubble level. If the rail needs to be adjusted, use the swivel levelers to level the machine.

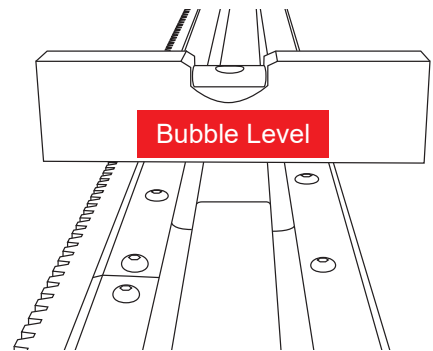

### Tip

*If the machine is equipped with the material cooling system, it is recommended that the back of the rail be set slightly higher than the front.*

## Reminder

If the machine is bolted to the floor, the bolts securing the floor brackets should be loosened enough so the swivel levelers can be adjusted properly to level the rail, and then re-tightened.

## Adjusting Swivel Levelers

1. To adjust the swivel levelers, ensure the jam nut is loose and backed off to the base of the swivel leveler.
2. Place an  $1\frac{1}{16}$  in. wrench on the hex adjustment at the base of the swivel leveler.
3. When viewing from above, turn clockwise to raise the leg, turn counter clockwise to lower the leg.

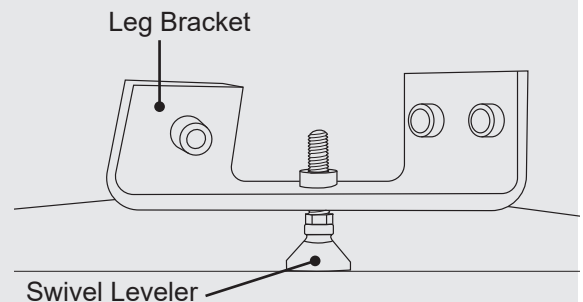

## Important

The swivel levelers should be installed during machine assembly.

### 2.2.3 Check Rail Straightness

Ensuring the Dragon A400 is straight and level is one of the most important steps in preparing the machine for operation. Each machine comes with a length of string specific to that machine. The string is located in the Miscellaneous box.

1. Locate the two screws, one at the head and one at the tail of the machine, that are partially unscrewed.
2. Hook one end of the string around the screw at the head of the machine, and the other end of the string around the screw at the tail of the machine.
3. Verify the string is even with the tops of the screw installed in each of the support legs. The string should be flush with the top of each screw along the length of the machine, as pictured.

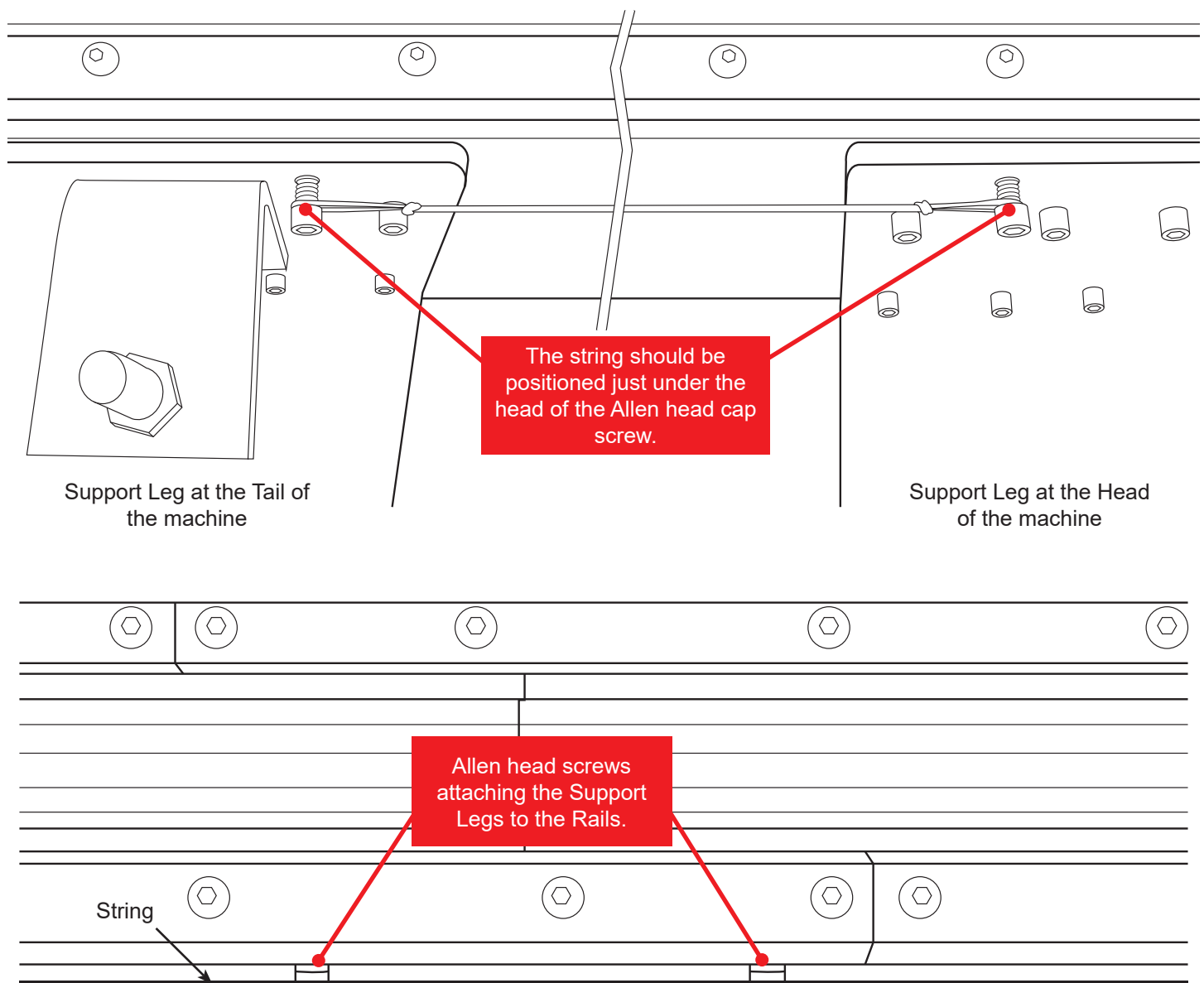

## 2.3 Electrical Inspection

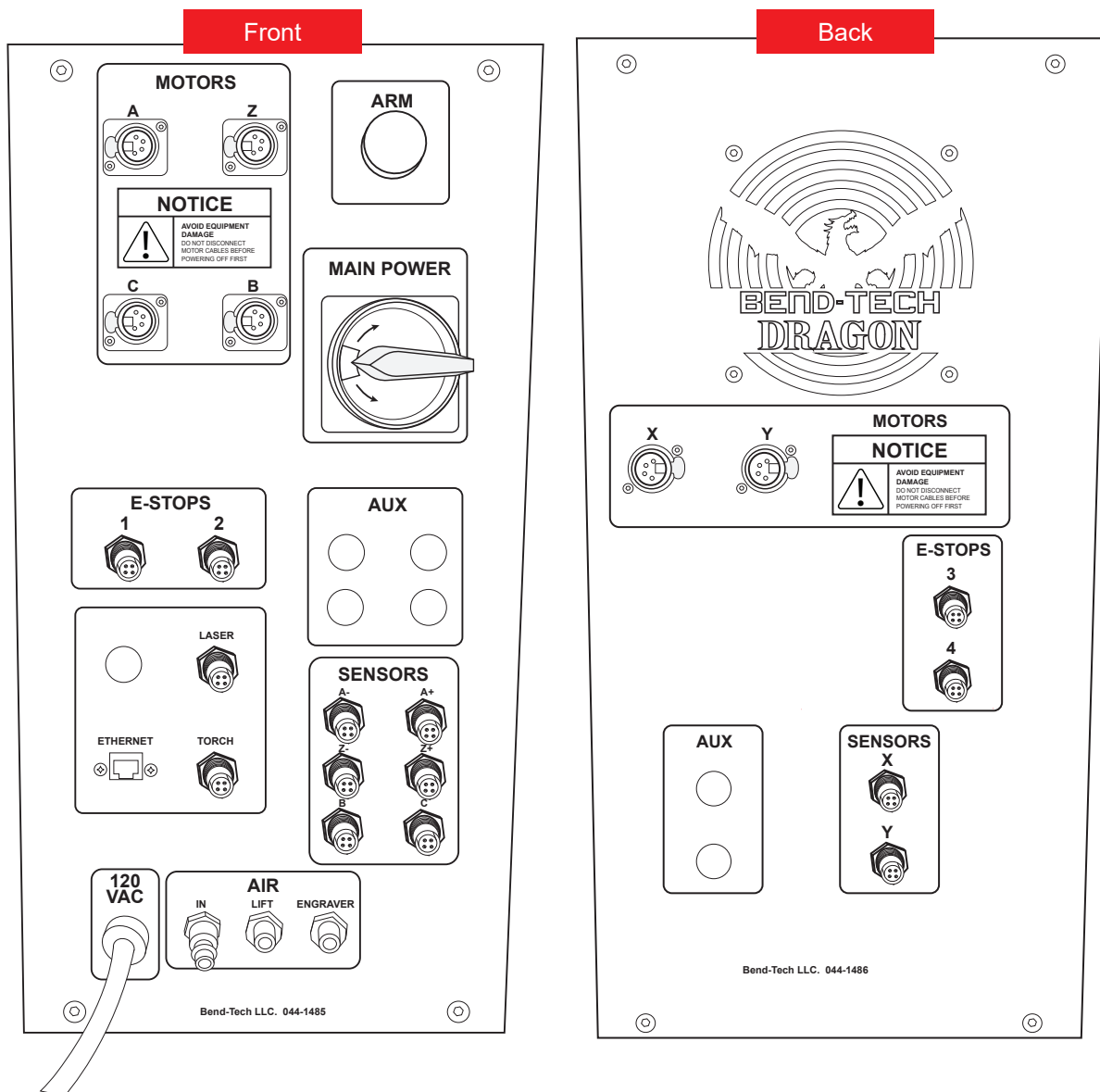

Ensure all cables are properly inserted and secured in their respected connectors. This is important for maintaining electrical connection to all the motors and sensors required for the Dragon A400 to operate. Only one end of the motor cables, homing sensor cables, and emergency stop cables are connected at the Bend-Tech factory. During machine assembly, the other end of the cables should be connected to the control box.

### ! Warning !



Before checking the electrical connections, ensure that the machine is off and disconnected from power.

### 2.3.1 Motor Cables

The motor cable connections are split between the front and back of the Control Box. The X-Axis and Y-Axis motor cable connections are located on the back and the A, Z, B, and C-Axis motor cable connections are located on the front. The C-Axis motor cable is only used for Powered Gate Dragon machines and will not be used for Non-Powered Gate machines.

## Important

If it is necessary to remove a motor cable or axis sensor cable, it is critical to the operation of the machine that they are re-connected to the correct socket. Failure to do this will result in improper function of the machine and could possibly damage the machine.

1. Ensure all motor cables are securely inserted into their control box connections and that their retaining clips are in place. There will be an audible click when the cables are connected correctly.
2. At the toolhead, there are two motor cable connectors. Ensure these are tight. Do not overtighten.
3. There is one motor cable for the material support lift. Pull the connector out through the hole in the back of the lifter case, and ensure it is tight.

## ! Caution !



It is possible for improperly fitted connectors to overheat and melt. This can damage the connector and affect the operational status of the machine. In extreme cases it could cause a risk of fire.

### 2.3.2 Motor Cable Locations

Axis	Location	Operation
X	Trolley	Moves Trolley forward/backward
Y	Chuck	Rotates chuck clockwise/counter clockwise
Z	Tool Head	Moves Tool Head up/down
A	Tool Head	Moves Tool Head left/right
B	Material Support	Raises/lowers material support
C	Front Gate	Rotates Front Gate clockwise/counter-clockwise

### 2.3.3 Axis Sensor Cables

The X and Y-Axis sensor cable connections are located on the back of the control box, the A-, A+, Z-, Z+, B, and C-Axis sensor cable connections are located on the front.

1. Ensure all axis sensor cables are securely seated in their control box connections and that they are tight. Do not overtighten the sensor cables. Doing so could damage the connections.
2. At the toolhead, there are four axis sensor cable connectors. Ensure these are tight. Do not overtighten.
3. There is one axis sensor cable for the material support lift. Pull the connector out through the hole in the back of the lifter case, and ensure it is tight.

## Important

While tools are not recommended when tightening cable connectors, rarely they may require tools to loosen them. Should this issue arise, care should be taken not to damage the connectors.



### 2.3.4 Emergency Stop Cables

There are four emergency stop (E-Stop) cable connections. 1 & 2 are located on the front of the Control Box, 3 & 4 are located on the back of the control box. The cables are labeled to match.

1. Ensure the E-Stop cables are securely seated and tightened.

#### Note

*When looking at the front of the machine, E-Stop #1 is on the left side of the head. E-Stop #2 is on the right side of the head. E-Stop #3 is the Chuck Trolley, and E-Stop #4 is located at the rear of the machine.*

### 2.3.5 Ethernet Port

The ethernet connection is how the Dragon A400 computer communicates with the machine. The ethernet cable should be connected directly from the ethernet connection on the Control Box to the ethernet connection on the computer. Connect the computer to the internet via wifi.

1. Ensure that the ethernet cable that connects the Dragon A400 computer to the control box is connected and securely clipped into place.
2. Ensure the ethernet cable is connected directly to the Dragon A400 computer. Do not use adapters. A link light at the ethernet port indicates proper connection.

## Important

Do not connect the Dragon computer to the machine via a router. Do not connect the ethernet cable to the Dragon computer via a USB adapter. Always connect the ethernet cable directly from the machine's ethernet port to the computer's ethernet port.

## Important

It is always best to route the ethernet cable away from other electrical cables. Any interference with, or interruption of, the ethernet signal can affect the operation of the Dragon machine. This includes the torch and motor cables, which can create significant electrical interference with the ethernet cable, which disrupts the signal between the computer and the machine.

### 2.3.6 Laser Light Connection

The laser light connection is located just above the torch connection on the front of the control box. The laser light cable is identified by a red plastic identification fitting on the wire connection.

1. Ensure the laser light cord is plugged in all the way.

### 2.3.7 Torch Connection

The torch connection for the Dragon A400 is located just below the laser light connection on the front of the control box.

1. Ensure the torch cable is connected securely. The other end of the torch cable connects to the plasma unit. The torch cable is located in the Miscellaneous box.

### 2.3.8 Connect the Ground Cable

Grounding the torch is key to proper operation of the torch. One end of the ground cable will be attached to the trolley at the Bend-Tech factory. This connection should not be altered.

1. Connect the other end of the ground cable to the ground cable leading from the plasma unit. Hypertherm plasma units come with an Alligator clamp. Ensure the connection between the Dragon ground cable and the Hypertherm clamp is secure.

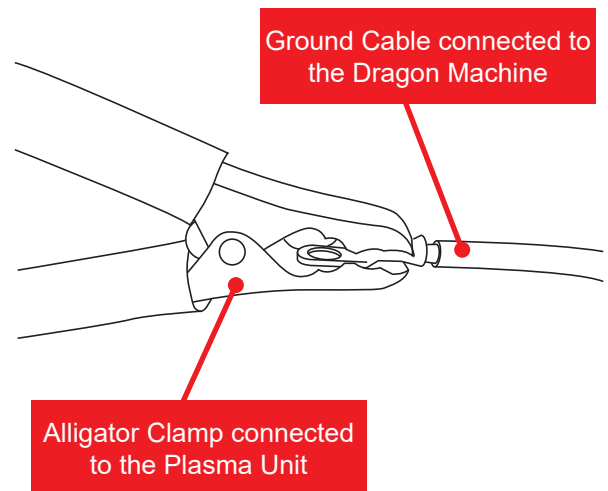

## Important

Bend-Tech recommends attaching the ground cables together with a bolt.

### 2.3.9 Check the Breakout Board

Before connecting power to the Dragon machine, open the removable control box cover. There are 12 screws that will need to be removed. The Breakout Board is the red circuit board near the top of the control box. It is seated on the motor control drivers.

1. Ensure that it is seated properly onto the drivers by pressing down on it at each of the driver connectors as shown in the image.

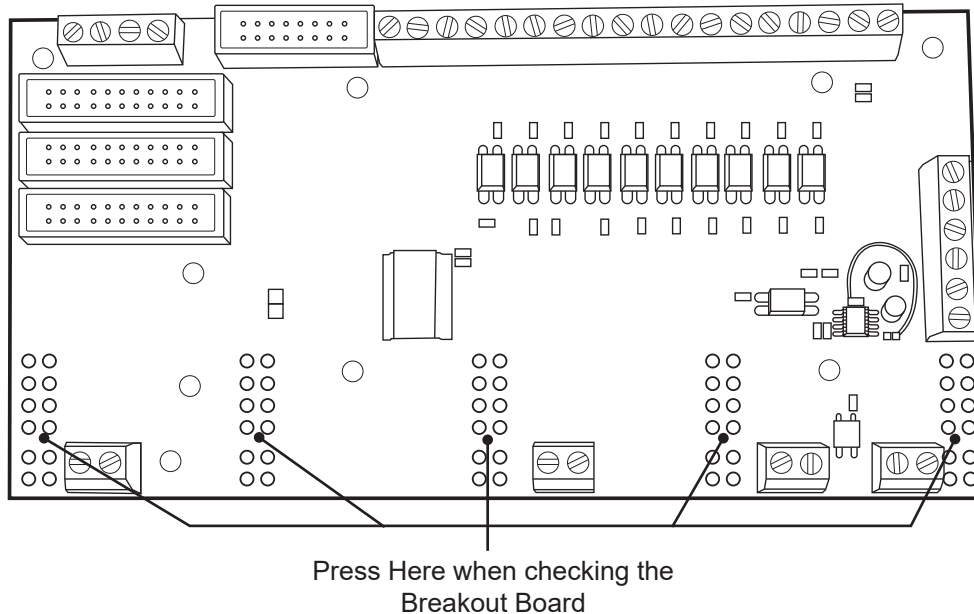

## Important

Leave the Control Box Cover off for the next step

### 2.3.10 Connect Power and Check for 5 Volts

The Control Box requires access to a 110 VAC outlet with 15 amps. It should be on a dedicated circuit.

1. Ensure that the main power cord is connected securely.
2. Turn the Main Power switch to the on position and ensure that the 5 volt indicator lights up.
3. Turn the power off and re-install the Control Box Cover.

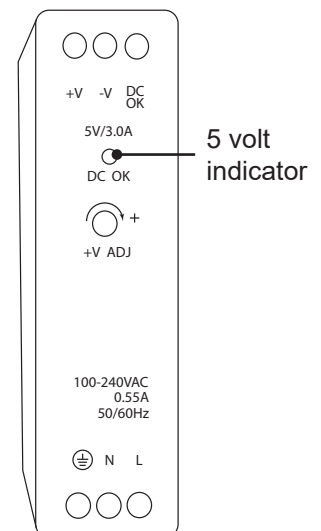

### 2.3.12 Check E-Stops

There are 4 E-Stops on the Dragon that need to be checked before engaging the Dragon motors. If the E-Stops are pushed in, that indicates that the E-Stop is triggered and there won't be power to any of the motors.

1. Ensure all of the E-Stops are dis-engaged.
2. Turn on the Main Power.
3. Press the green ARM button on the control box. Only press the button once, and do not hold down the button. The green ARM button turns the power on to the Dragon motors.
4. Press one of the E-Stops. This should turn off the ARM button.
5. Dis-engage the E-Stop that was pressed. Press the ARM button again, and repeat this test for all of the E-Stops.

## 2.4 Air Line Connection

---

The Dragon A400 requires two air line feeds. One air line hose is connected to the air inlet on the control box and the second air line hose is connected to the plasma unit. A single source air line can feed both units if split with a T-junction.

The air line connections for the machine are located near the bottom on the front of the control box. The air line connections for the engraver and material support lift are pneufit push-in style connectors.

1. Ensure the plastic air lines for the engraver and material support lift are securely seated and are not leaking at the connection points.

## 2.5 Material Coolant System

---

If the Dragon A400 machine was purchased with a Material Coolant System, ensure the hose is connected to the valve on the trolley. See the Material Coolant System manual for more information on installing the Material Coolant System.

# Machine Control Startup

## 3.1 Machine Control Startup

Booting up the Dragon A400 requires following a specific procedure. Following this procedure in the proper order will ensure the Dragon A400 is up and running as quickly as possible. Failure to follow the procedure in the proper order can affect machine operation and lead to unnecessary down time.

## 3.2 Booting Up The Dragon A400

### 3.2.1 Power On Computer

The Dragon A400 is shipped with a new Dell Inspiron computer preloaded with Bend-Tech Dragon software, as well as Newfangled Solutions Mach3 six-axis CNC controller software package. The Bend-Tech Dragon software uses Mach3 to communicate with the control box on the machine. With the Bend-Tech Dragon software the operator can create single parts, import projects, and control the machine.

Power on the computer by pressing the power button located on the front of the unit. Make sure the power cord is plugged in to a reliable power source. It is highly recommended that electronics such as the computer be protected from power surges by a surge protector.

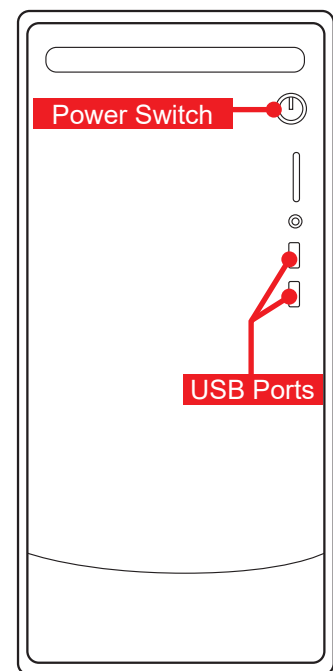

## 3.3 Power On Control Box

### 3.3.1 Main Power Switch

On the Dragon A400 control box, flip the Main Power Switch to ON (when ON the side of the rocker switch with the “-” symbol will be depressed).

### 3.3.2 Green Power Button

With the Main Power Switch ON, press the Green Power Button. It will light up.

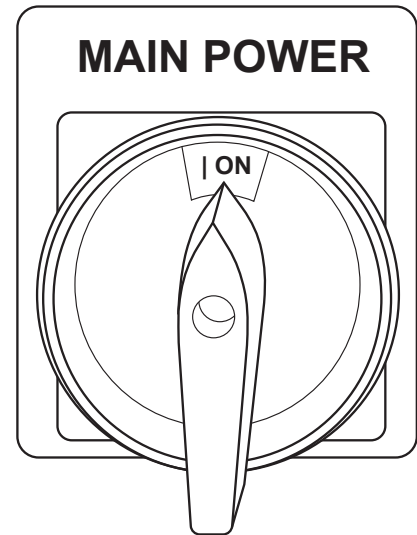

## Important

If the Green Power Button does not stay lit it is likely due to an E-Stop that has been triggered. In this case check all E-Stop buttons.

### 3.3.3 Launch Bend-Tech 7x

On the computer desktop, locate and click the Bend-Tech 7x icon to launch the software. The Bend-Tech Launcher will open showing options to launch Dragon CAD, Dragon CAM and Dragon CAD + Dragon CAM. The Dragon A400 is operated fully with the Dragon CAM software. Dragon CAD software is used to design assemblies for production.

### 3.3.4 Dragon A400 Software Color Designations

Software	Color	Function
Dragon CAD	Blue	Assembly Design
Dragon CAM	Orange	Dragon A400 Operation
Dragon CAD + CAM	Both Screens Open	Assembly Design and Dragon A400 Integration

### 3.3.5 Bend-Tech Launcher

Click on Dragon CAM from the Bend-Tech Launcher to start the Dragon operational software.

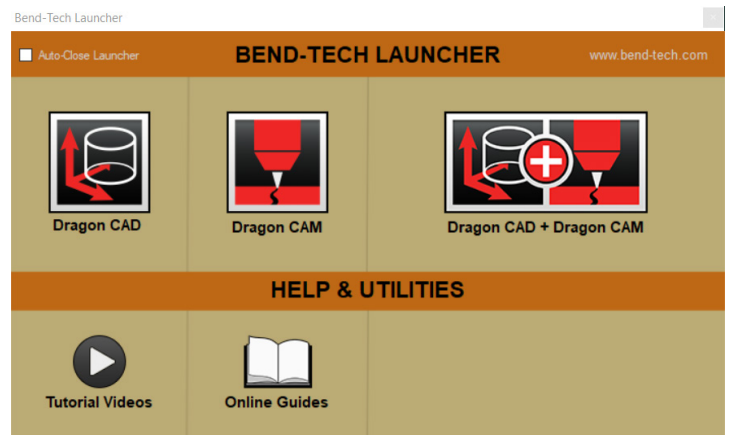

### 3.3.6 Machine Control



At the top of the screen, click MACHINE CONTROL.

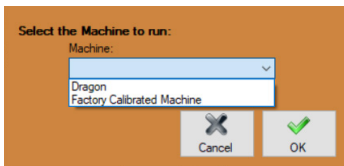

Click the down arrow next to the Machine Selection window. Select the Dragon machine.

Click OK. Mach3 software will open at this time.

### Note

*In some cases, if there is only one machine entered in the Machine Library, the program may go straight to Mach3 and not present a Machine Selection window after clicking Machine Control.*

## Important

If Mach3 does not connect properly repeat the Power On procedure beginning at Section 3.3.1.

### 3.3.7 Mach3 Machine Control

Mach3 CNC software control interface will appear. Minimize Mach3, the operator will primarily work in the Bend-Tech Machine Control interface when operating the Dragon A400.

Machine Control interface

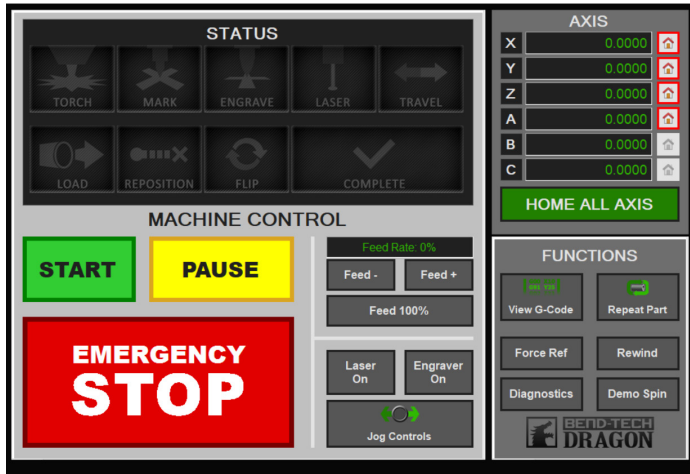

Mach3 CNC Machine Control interface

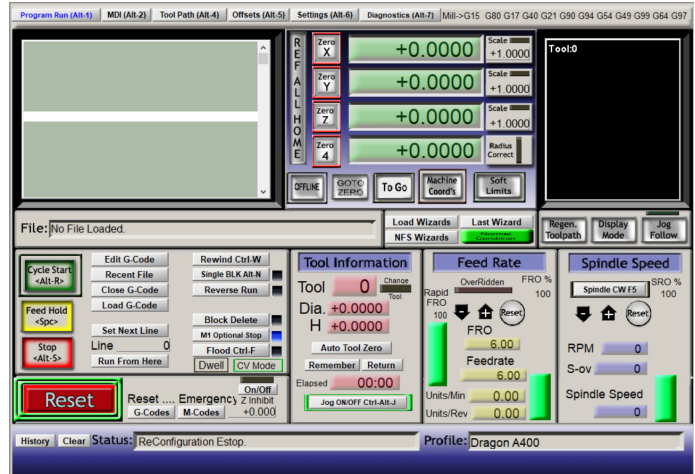

### 3.3.8 Enable Machine

Upon initial startup, the Machine Control screen will be mostly grayed-out and a red “Machine Disabled - Press Here To Enable Machine” button will be flashing.

Click on “Machine Disabled - Press Here To Enable Machine.” The Dragon A400 is now enabled.

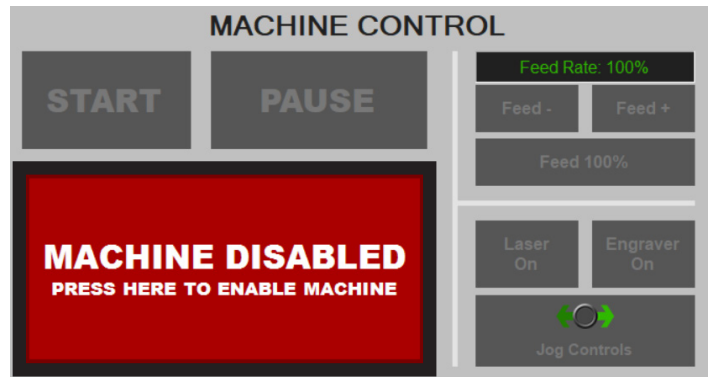

## 3.4 Jog Controls System Check

Upon initial startup it is important to verify all motors are working as intended. Use the Jog Controls feature to verify proper machine operation.



### 3.4.1 Open Jog Controls

At the bottom center of the Machine Control screen, click Jog Controls to open the Jog Controls interface screen. Jog controls are referenced to their respective motor (see Motor Location and Operation Index table 3.4.2).



# ! Caution !



Avoid jogging the machine to the limits of its operation.

## 3.4.2 Motor Location and Operation Index

Jog Control	Operation	Jog Control	Operation
X++	Trolley Forward	A++	Tool Changer Left
X-	Trolley Backward	A-	Tool Changer Right
Y++	Chuck Clockwise	B++	Material Support Lifter Up
Y-	Chuck Counter-Clockwise	B-	Material Support Lifter Down
Z++	Tool Changer Down	C++	Powered Gate Clockwise
Z-	Tool Changer Up	C-	Powered Gate Counter-Clockwise

## 3.4.3 Jogging the Machine

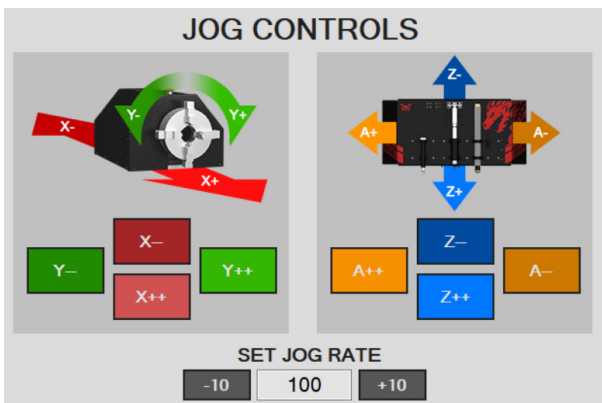

With the Jog Controls screen open, jog the Dragon A400 to observe that all controls are in working order.

On machines equipped with a powered gate, use coordinated rotation to job the C-Axis and Y-Axis.

## 3.5 Homing The Machine

Before beginning operations with the Dragon A400, the machine must determine Home for all of its operating Axes. This allows the machine to operate efficiently and within its operational parameters.

### 3.5.1 Homing an AXIS

The AXIS feature on the Machine Controls screen allows the operator to Home each Axis of the Dragon A400. Each Axis is labeled according to its corresponding moving feature as defined in the Axis Definition Table 3.5.2.

To home an individual Axis click the House icon corresponding to the Axis on the right hand side of the AXIS feature.

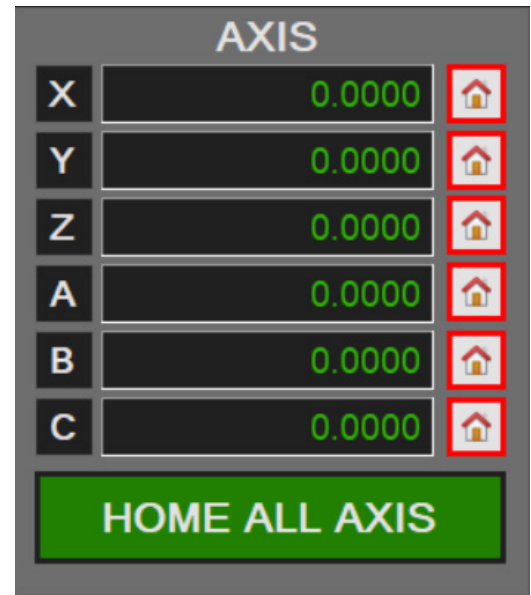

## Important

Do not Home any Axes at this time.

### 3.5.2 Axis Definition Table

Axis	Definition
X	Trolley
Y	Chuck
Z	Tool Changer Up/Down
A	Tool Changer Left/Right
B	Material Support Lifter
C	Powered Gate

### 3.5.3 Jog the Trolley

To speed up the Homing procedure jog the Trolley near the end of the Rail, so it has less distance to travel to contact the X-Axis homing switch.

## Note

*All the Axes move in a negative direction to Home.*

## ! Caution !



When jogging the Trolley to the end of the Rail allow it time to decelerate. If the Trolley contacts the end of the Rail the Operator will see a Machine Disabled signal. This is a safety feature designed to protect the Dragon A400 from being damaged. The Operator will need to click Enable Machine to resume machine operation.

### 3.5.4 Home All Axis

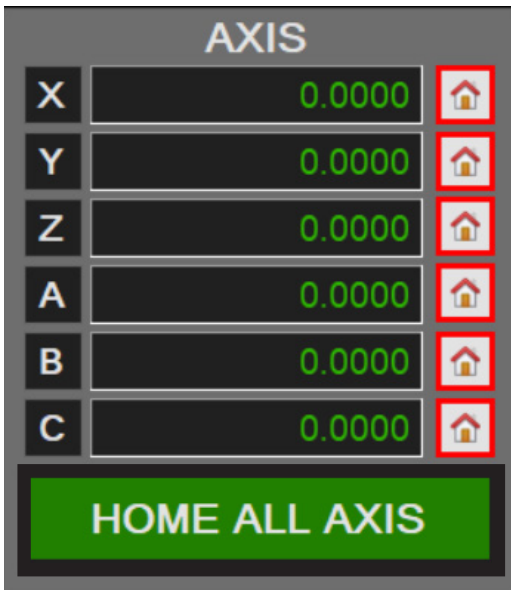

Each axis can be individually homed or choose HOME ALL AXIS to home all of the axes in sequence. Upon initial machine startup the operator should choose HOME ALL AXIS and allow the machine to complete this action.

Click HOME ALL AXIS. This procedure will take a few minutes. The Operator should observe the procedure to ensure all Axes are safely homed by the program with no interference.

## Important

House icons will turn green when the Axes are homed.

## 3.6 Hypertherm

---

Powering on the Hypertherm plasma cutting machine is the last step in preparing the Dragon A400 to run. The Operator should have set up and connected the Hypertherm according to the procedures outlined in section 1.7.

### Important

Ensure the Hypertherm unit is set to cut the type of material or to perform the cutting procedure as intended. The Hypertherm will go to default PSI settings. However, the Operator will need to adjust amperage as necessary.

### Important

The controls for the Hypertherm Powermax45 and Powermax65/Powermax85 are different. The Operator should familiarize themselves with the controls of the Hypertherm unit using the Operator's Manual found in the box.

### 3.6.1 Hypertherm Power Switch

The power switch for the Hypertherm Powermax45 is located on the front of the machine. It is a rocker switch. Press "I" to power on the unit. The power switch for the Hypertherm Powermax65 and Powermax85 is located on the back of the machine. Turn it clockwise to power on the unit.

### ! Caution !



Ensure the Hypertherm ground clamp is connected to the Dragon A400 ground wire.

### Important

Ensure the air supply is connected to the Hypertherm.

### 3.6.2 Hypertherm Cut Type

The Standard Cutting mode is the most common setting that will be used with the Dragon A400. On the Hypertherm this is typically the second mode down (clockwise) on the cutting mode switch.

### 3.6.3 Hypertherm Air Supply

The Hypertherm Powermax45 minimum air supply requirement is 6 cubic feet per minute (cfm) at 90 psi. When cutting thicker material it is possible that the Hypertherm unit will require higher air flow from the air supply. The Customer should ensure the air supply for the Dragon A400 is appropriate to operate the Hypertherm as well as other working aspects of the machine. If connected to a separate air source the Customer should ensure the air source is appropriate to supply the Hypertherm unit. See section 1.7.5 for Hypertherm air supply requirements.

### 3.6.4 Hypertherm PSI Settings

The Hypertherm unit will be pre-set to a default PSI. This is the recommended starting point for cutting operations on the Dragon A400.

### 3.6.5 Hypertherm Cut Settings

As a rule, speed and amperage settings should be on the low end of what Hypertherm recommends for a given material. For any given cut, Bend-Tech recommends dividing the recommended Hypertherm feed rate in half as a starting point of operation.

The Dragon A400 machine parameters are now set.



## **Attention**

After reviewing the Startup Manual Part 2,  
please proceed to Startup Manual Part 3.

**Bend-Tech, LLC**

729 Prospect Ave. Osceola, WI 54020  
1-651-257-8715

[sales@bend-tech.com](mailto:sales@bend-tech.com)  
[www.bend-tech.com](http://www.bend-tech.com)